

WARD: Filwood

SITE ADDRESS: Filwood Park Playing Fields Creswicke Road Bristol BS4 1UA

APPLICATION NO: 23/03423/FB Full Planning (Regulation 3)

DETERMINATION DEADLINE: 8 November 2023

Proposal to construct a new Multi Use Games Area (MUGA) at Filwood Playing Fields including floodlighting, fencing, seating areas, fitness equipment, pedestrian and vehicle maintenance routes and landscaping.

RECOMMENDATION: Grant subject to Condition(s)

APPLICANT: Bristol City Council
City Hall
Bristol
BS1 5TR

The following plan is for illustrative purposes only, and cannot be guaranteed to be up to date.

LOCATION PLAN:

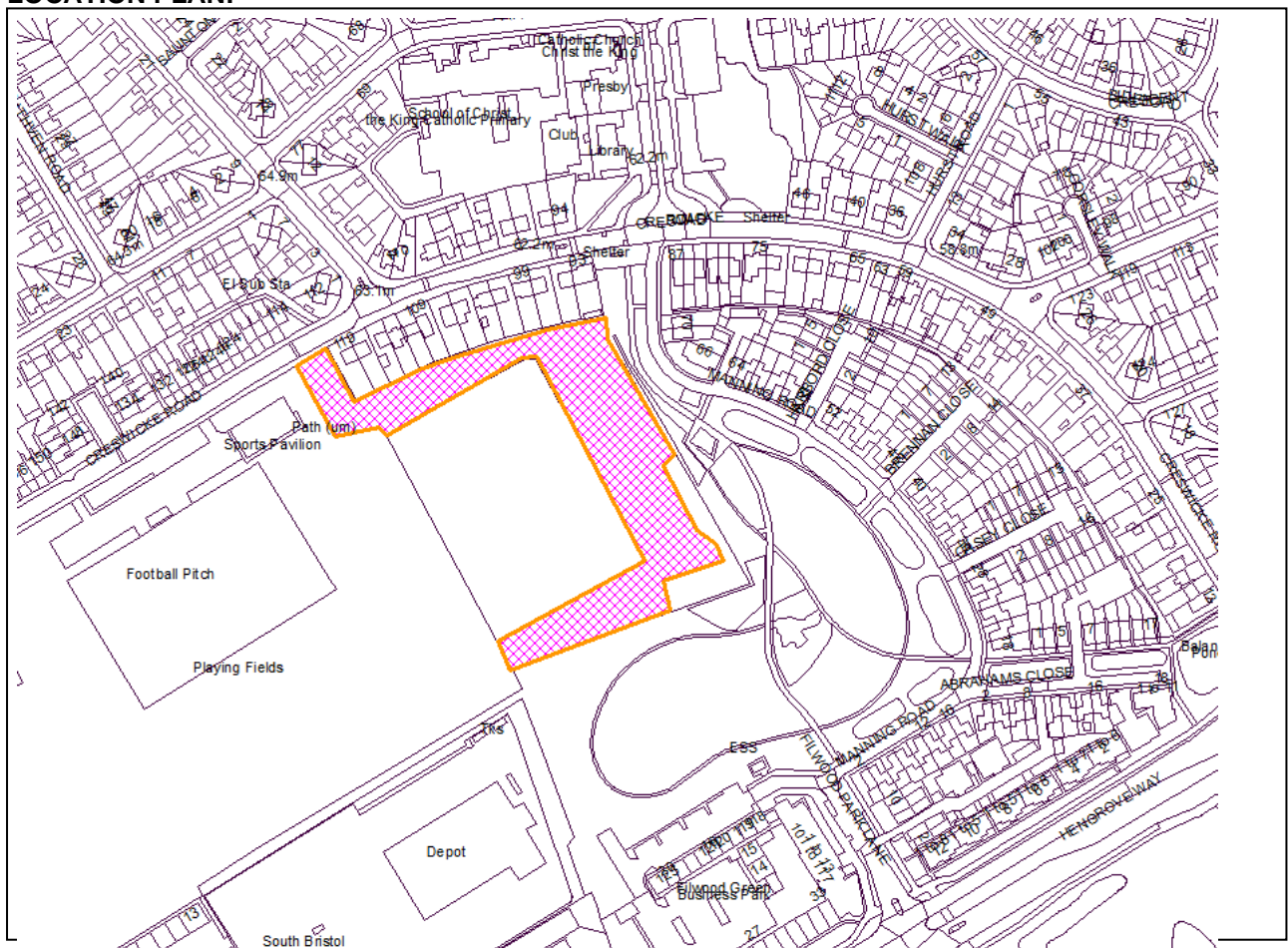

Development Control Committee A – 24 January 2024

Application No. 23/03423/FB : Filwood Park Playing Fields Creswicke Road Bristol BS4 1UA

BACKGROUND AND SUMMARY

This application is for planning permission for a new Multi Use Games Area (MUGA) at Filwood Playing Fields including floodlighting, fencing, seating areas, fitness equipment, pedestrian and vehicle maintenance routes and landscaping.

To account for the submission of further information, amendments made to the application and revisions secured to address concerns raised by Officers two rounds of public consultation were undertaken. These generated 41 (first consultation) and 2 (second consultation) objections. 2 letters of support were also submitted to the first consultation.

The objections predominantly raise concerns in relation to the impact of the development on the amenity of surrounding residential properties with regards to noise pollution, light pollution, safety and security including anti-social behaviour issues (see full details of the objections below and on the BCC website).

Due to the level of public interest it is considered appropriate for this application to come before Committee.

Initial concerns were raised by Officers in relation to the impact of the development on the amenity of surrounding residential properties with regards to noise and light pollution. The concerns regarding safety, security and anti-social behaviour were also acknowledged.

As such, further information and revised plans were provided, which included additional detail in relation to measures to reduce the risk of crime and limit the impact of noise and light on surrounding residential properties.

The MUGA activity zone will be sited at least 30 metres away from all neighbours, floodlighting will be switched off at 8pm and the facility has been designed so that it can be secured at night, with gates that could be locked in the future by the Council's Parks Team, if necessary, should noise/disturbance become an apparent problem. The use of CCTV, the facility being designed so that it could be secured at night, features in place to prevent unauthorised vehicular access and the commitment to regular maintenance and monitoring by the Council's Parks Team (as detailed in the approved Management Statement) will further help reduce the opportunity for crime arising from the proposal.

Issues related to access, highway safety, design, ecology, impact on trees, flood risk, land contamination and local sports provision have also been considered by Officers and are deemed acceptable.

Officers acknowledge that there is no way to completely eliminate the risk of noise and disturbance arising from the proposed MUGA, nor is it possible to eliminate the risk of crime completely. The nature of the facility is such that noisy activities may arise. However, given the amendments made to the scheme, nature of development and restrictions placed on the facility (secured via condition) the LPA is satisfied that the proposal is policy compliant in that crime and disorder and fear of crime has been considered in the design stage of the development, and the proposal is not considered harmful enough to the amenity of surrounding residential properties with regards to noise and disturbance to warrant refusal when weighed in the balance with the significant community, recreation and health benefits associated with the new MUGA facility.

Approval is therefore recommended to Members, subject to conditions.

Development Control Committee A – 24 January 2024

Application No. 23/03423/FB : Filwood Park Playing Fields Creswicke Road Bristol BS4 1UA

SITE DESCRIPTION

The application site is located at Filwood Fields, off Creswicke Avenue in Filwood. It is adjacent to Filwood Park and set within land owned by Fields in Trust. It is currently made up of long grass and shrub.

The floodlit Mendip Broadwalk Football pitch is located immediately to the west and south of the site. To the east, lies the Filwood Park Community Hub and a landscape buffer of Public Open Space within the Filwood Park housing development of 150 homes.

The closest properties within this new development are located at Manning Road, the boundary of these properties being located approximately 32 metres to the east of the proposed MUGA at the closest point. The properties themselves along Manning Road are approximately 36 metres away from the proposed MUGA at the closest point. Further residential properties exist at Creswicke Road to the north, with the closest property boundary located approximately 35.5m away from the site. The properties themselves are approximately 50 metres away.

The application site is designated as Important Open Space (Filwood Playing Fields) within the Site Allocation and Development Management Policies (2014).

RELEVANT HISTORY

No relevant site history.

APPLICATION

Planning permission is sought for the provision of a Multi Use Games Area (MUGA) at the site.

The MUGA will consist of a macadam ball court measuring 38m x 20m with a 4m wide footway surrounding the court, with a total area of 1,276 sqm. The ball court will include football goals, basketball and netball nets. It will also include colourful line marking to enable a range of other activities.

A 4m high metal mesh fence is proposed to surround the MUGA. 2 chicane style wide accessible entrances are included.

Four 8m high Philips LED floodlights are also proposed. CCTV will be attached to the floodlighting.

The ball court will be flat with and the access pathway will be 1:110 enabling disabled access.

A seating area with shelter, as well as Sheffield cycle stands, are proposed to the northern end of the MUGA.

To the southern end of the MUGA there will be an area for proposed exercise equipment.

The proposals include a 3m wide pedestrian pathway from the north, to link up with Creswicke Road. The access route will also be wide enough to ensure that the MUGA can be serviced and maintained by the Bristol Council Parks team. The access route will be constructed using heavy duty permeable plastic paving grids which aim to reduce any ecological disturbance. A secondary emergency access route would be possible for pedestrians to the south.

Development Control Committee A – 24 January 2024

Application No. 23/03423/FB : Filwood Park Playing Fields Creswicke Road Bristol BS4 1UA

EQUALITY ASSESSMENT

The public sector equalities duty is a material planning consideration as the duty is engaged through the public body decision making process.

"S149 of the Equality Act 2010 provides that a public authority must in the exercise of its functions have due regard to:-

- a) eliminate discrimination, harassment, victimisation and any other conduct prohibited under the Act
- b) advance equality of opportunity between persons who share a relevant protected characteristic and persons who do not share it
- c) foster good relationships between persons who share a relevant characteristic and those who do not share it."

During the determination of this application due regard has been given to the impact of the scheme upon people who share the protected characteristics of age, disability, gender reassignment, marriage and civil partnership, pregnancy and maternity, race, religion or belief, sex and sexual orientation.

The application is supported by an Equality Impact Assessment, which confirms that the MUGA has been designed in consultation with the local community. Specific elements of the design related to equalities include:

- The MUGA will include wide entrances and accessible paths to allow disabled people to access the facility.
- Safety and security measures have been included in the design.
- The facility looks to tackle deprivation levels by providing a new high-quality facility to replace an existing MUGA that has fallen into disrepair.
- The MUGA has been designed to be accessible and welcoming for the whole community, including protected groups.

STATEMENT OF COMMUNITY INVOLVEMENT

The proposed development is classed as 'minor' development; therefore there is no requirement for the applicant to demonstrate community engagement prior to submitting the application.

However, the applicant has submitted a Statement of Community Involvement which sets out the following:

a) Process

In respect of public consultation, the applicant has confirmed that significant engagement has been undertaken on this project which includes the following key items:

- Three public consultation and engagement events, February 2023
- Engagement with Knowle West Alliance
- Community engagement at local events, June to August 2023
- Targeted youth group engagement with Youth Moves and Knowle West Media Centre Youth Council, June-July 2023
- Formal consultation to residents, July 2023
- Ward member briefing, July 2023
- Consultation with Sports England, July 2023

Development Control Committee A – 24 January 2024**Application No. 23/03423/FB : Filwood Park Playing Fields Creswicke Road Bristol BS4 1UA**

b) Outcomes

In response to the outcome of consultation/engagement, the following alterations were made:

- Amendments made to the design to include two wide MUGA entrances, fitness equipment and seating equipment.
- Commitment to future engagement with youth groups to determine the MUGA colour scheme and design of the seating and fitness equipment.
- Commitment to provide a ball court which has basketball nets, football goals and netball posts
- Production of a floodlighting survey, ecology survey and BNG assessment

RESPONSE TO PUBLICITY AND CONSULTATION

The application was initially advertised via press and site notices, expiry date 18.10.2023. Neighbours were also initially consulted via individual letters sent on 20.09.2023.

Objections initially received from 41 no surrounding residential properties, which in summary stated that:-

- The development would result in noise and disturbance to the detriment of the amenity of surrounding residential properties
- The development would result in light pollution to the detriment of the amenity of surrounding residential properties
- The development would result in increased crime and anti-social behaviour issues
- The proposed access to the MUGA from Manning Road is inappropriate and will result in issues for existing residents
- The development would result in a loss in privacy for surrounding residential properties
- The vehicle access route will result in safety issues for pedestrians and cyclists
- The development will result in an increased number of cars accessing the local area, which will result in congestion issues and loss of parking spaces for existing residents
- The submitted documents do not provide any highways assessment
- No details of any gates or barriers are shown to prevent unauthorised vehicle access
- There is an existing MUGA in the local area which should be repaired and re-used
- There are already enough MUGAs in the local area; this new one isn't needed
- The development will result in a loss of wildlife habitat and will result in ecology issues
- The development has failed to consider the impact of the proposal on bats
- The development should not be built on green space
- The development will attract litter
- The management and maintenance responsibilities (including emptying of bins) is not clear
- The development will lead to increased maintenance and security burden for existing residents
- The MUGA should be sited away from residential properties
- There is no consideration of alternative options within the wider Filwood Park to locate the MUGA
- It is unclear how the Council will ensure the facility is used equally by girls
- The application shows development taking place outside of the red-line boundary which isn't deliverable
- The submitted red-line plan is incorrect

2.no letters of support initially received, which in summary stated the following:-

- The proposed facility be a positive asset for the local community, providing an opportunity to play sports
- The cost of hiring sports facilities is rising so this is an important free facility
- The existing MUGA (which is subject to redevelopment) is located less than 100 metres away
- The boundary treatment could be planted with landscaping to create natural separation from

Development Control Committee A – 24 January 2024**Application No. 23/03423/FB : Filwood Park Playing Fields Creswicke Road Bristol BS4 1UA**

neighbouring houses

Following concerns raised by Officers and neighbours the scheme was amended, with additional information submitted. Following the submission of this information neighbours were re-consulted, via individual letters sent on 08.12.2023

Objections received from 3.no neighbouring properties following re-consultation, which in summary stated that:-

- The timeframe for providing comments is not sufficient
- The development would result in noise and disturbance to the detriment of the amenity of surrounding residential properties
- The development would result in increased crime and anti-social behaviour issues
- The development could result in light pollution

OTHER COMMENTS

Councillor Tom Renhard has commented as follows:-

'I write to give full support to the proposal to construct a new Multi Use Games Area (MUGA) at Filwood Playing Fields.

The MUGA proposals will provide a much needed, high-quality sports and recreation facility for Filwood. With a flexible games court, additional fitness apparatus and seating, the MUGA will offer a variety of amenities to encourage activity, recreation and use by all.

The new MUGA will directly compensate for the loss of the existing MUGA at Filwood Broadway, which has fallen into significant disrepair. It is essential that a new MUGA is constructed in Filwood to combat the loss of these facilities in the wider Filwood area.

The MUGA will target low satisfaction in leisure facilities in Filwood, where only 15.4% of Filwood residents are satisfied with activities available to children and young people. As we emerge from the pandemic, the effects of isolation and social dislocation on young people, especially those in more disadvantaged communities, is becoming more apparent and investments such as the new MUGA provide the opportunity to shape and plan a better future for the children and young people of Filwood.

Following extensive engagement with the local community, particularly children and young people, the facility has been designed to ensure it meets their needs.

The MUGA will be funded from a combination of Council investment and the successful 'Transforming Filwood' Levelling Up Fund bid. It will complement significant investment proposed to regenerate the Filwood Broadway high street where improved community facilities will promote the revival of a busy, fun and welcoming place at the heart.'

Filwood Broadway Working Group has commented as follows:-

'1. These comments are submitted by Filwood Broadway Working Group. The group has been working with the local community and BCC for the past three years -

"A partnership that delivers development for the future, that is community driven and inspired, bringing a mix of sustainable good quality facilities; retail; affordable homes; community buildings, leisure and play alongside a pleasing public space through structural improvements making Filwood Broadway a destination place where people can live, work, play and shop. "

These comments are informed by the context of Knowle West Regeneration Framework and Filwood

Development Control Committee A – 24 January 2024

Application No. 23/03423/FB : Filwood Park Playing Fields Creswicke Road Bristol BS4 1UA

Broadway Regeneration Plan and The Bristol Local Plan policies and site allocations.

2. In relation to the Knowle West Regeneration Framework

The proposals are a positive contribution towards the following objectives within the KWRF vision:

- 2) Improve health and well-being;
- 6) Access to safe, ecologically rich, open space;
- 13) Develop play and youth facilities by planning with young people.

3. We notice that the in the list of documents included in the Planning Portal there are a few missing:

Preliminary Ecological Appraisal

Landscape Management Plan

Also, a Construction Management Plan should have been provided, as there are likely to be implications for Manning Road and Creswicke Road.

4. The re-provision of the MUGA is not included in the BCC Local Plan Site Allocations. The site of the existing MUGA at Filwood Broadway falls below BSA1122, earmarked for business, retail and housing. Filwood Broadway Working Group is aware that redevelopment of the former swimming pool site is unlikely to progress successfully until the issue of the re-provision of the existing MUGA (located on the former swimming pool site) is resolved.

5. FBWG supports the re-provision of the MUGA at the Filwood Playing Fields in principle as this facility is much needed but we have the following concerns that we believe need to be addressed:

Our key points relate to:

- a) Consultation with residents living closest to the site of the proposed MUGA
 - b) Access arrangements to the MUGA
- a) Consultation with residents living closest to the site of the proposed MUGA

Filwood Broadway Working Group has considered the re-provision of the MUGA at many meetings over the past three years.

We acknowledge that the "Statement of Community Consultation" provides detailed information about the scope and breadth of consultation to date.

The Statement of Community Involvement summary states that "the design has been updated to reflect the wants and needs of the local community with the inclusion of additional facilities which promote inclusivity and the provision of facilities for all, whilst still providing a high quality MUGA facility to replace the existing provision. "

However, it is felt that further information on how responses were treated would be helpful.

In particular, there have been responses from near neighbours about fears/concerns of anti-social behaviour and how this would be managed. It is important to know how these concerns can be addressed.

Reassurance is felt necessary that the Police could monitor the area to enable any ASB to be managed by a multi-agency response. Reassurance is also felt necessary to ensure that the Parks Department would be able to maintain the area in the future.

Development Control Committee A – 24 January 2024

Application No. 23/03423/FB : Filwood Park Playing Fields Creswicke Road Bristol BS4 1UA

b) Access arrangements need to be confirmed. We understand that two access routes are proposed: one via Creswicke Rd for vehicle access to maintain the MUGA site; the other via Manning Road for vehicles and pedestrian access. However, we understand that access from Manning Road is not certain at this stage.

Safe pedestrian access to the MUGA is essential, including suitable lighting to ensure safety of young people particularly. The vehicle access from Creswicke Road is shown as having no lighting and is therefore unsuitable for pedestrians. The Manning Road/Filwood Park access must be resolved as part of this proposed development.

6. Other Comments:

- A construction management plan is needed to cover how the proposals are to be built which would take into account the effects of the construction period, even if short, on nearby housing and green space users.

- An ecological report to see whether there is anything ecologically valuable or not, whether habitats or species, within or using the existing grassland.

- Confirmation from the noise report whether the worse-case levels of noise modelled between 9pm and 10pm, would be experienced how many times in the year and what this would mean to houses nearby.

- How long was the land to be in the control of/or leased to the Council? To ensure that the facility if agreed, would be available.

- Better visualisations of the proposed design and landscaping proposals.'

BCC Archaeology Team has commented as follows:-

'Following consultation, the Councils Archaeology Officer noted that the area of the proposed development is known to have been occupied during the Romano-British period. Previous archaeological work in the vicinity has recorded well preserved evidence of a substantial agricultural community during the late Iron Age to Roman era.

The site itself has been subject to previous non-intrusive geophysical surveys that have suggested that there is limited archaeological evidence surviving beneath the playing field, possibly as a result of previous landscaping and drainage works. However, deeper archaeological features may be present.

Based on the submitted information and evaluation report referenced however, there is unlikely to be any impact to archaeological significance posed by this scheme. As such, the application is considered acceptable and there are no further archaeological requirements.'

BCC Urban Design has commented as follows:-

Verbal comments:

'The proposed columns would be unobtrusive given the limited bulk and massing of the structures and will appear in keeping with the surrounding context (sports fields). They will further be a limited height (8 metres) which will ensure they will not be overly visible from long distance views, nor will they appear prominent or incongruous additions within the local townscape.

The proposed MUGA will be surrounded by a 4 metre high ball court, mesh fencing system. This element of the scheme represents the most intense form of development, by virtue of its height and general design. However, the necessity for such fencing around MUGAs and ball courts is

Development Control Committee A – 24 January 2024**Application No. 23/03423/FB : Filwood Park Playing Fields Creswicke Road Bristol BS4 1UA**

recognised, and the fencing will retain some visual permeability through its mesh design to ensure it doesn't appear an overly solid or prominent addition to the open space or wider area. The MUGA and fencing will further be sited away from the public realm, with the site adjacent to existing established sports pitches. This will minimise its impact on the site's openness and will limit the visibility and prominence when viewed from the surrounding public realm and streets.

The associated ancillary structures and equipment (i.e. seating, exercise equipment) will be in keeping with the immediate context and character of the site (sports pitches). Further detail of these elements should be secured via condition to ensure it is of a scale and design which will not appear overly prominent with regards to the surrounding townscape.

The soft landscaping to be removed does not hold significant visual amenity value, being primarily long grass and shrubs not of a significant size. Further, the amount of soft landscaping removed would only equate to a very small proportion of the total soft landscaping within the open space.'

Avon and Somerset Constabulary Crime Reduction Unit has commented as follows:-

'In order to mitigate crime/ASB we would ask

- o The facility is secured overnight.
- o CCTV is capable of achieving 'identification' quality images (Home Office 28/09).
- o Features are in place to prevent unauthorised vehicular access.'

BCC Flood Risk Manager has commented as follows:-

'The flood risk posed to the site is deemed as relatively low from all sources of flooding.

A suitable means of drainage provision has been identified to serve the development. This includes porous macadam surfacing, French drains and soakaway trenches. The infiltration potential appears good from the ground investigation conducted and so the infiltrating SuDS methods should operate effectively. The regular maintenance schedule for the site will help continue their ongoing functioning. Such as relieving the risk of blockages occurring through routine sweeping and litter clearances. The removal of silt build-up in trenches and drains could be added to this to avoid clogging of the system over time.

It is noted that it states: "Drainage design to be confirmed once geo-technical survey is completed". Once this is firmly established please can the finalised drainage strategy be submitted for further review. This can be secured via condition.'

BCC Nature Conservation Officer has commented as follows:-

'The site is located in an urbanised area on a recreational (sports) site and is directly adjacent to the Airport Road Site of Nature Conservation Interest (SNCI). The site is not within the West of England Nature Partnership (WENP) Nature Recovery Network. It is not considered this development will have an impact to the SNCI site.

The Preliminary Ecological Appraisal (PEA) (Avondale Ecology, August 2023) appropriately describes the ecological features of the site and any mitigation required. The Reptile Survey Report (Avondale Ecology, September 2023) identifies mitigation and avoidance measures that must be in place to avoid the risk of killing/injury of reptiles present on site. Evidence that these are in place must be provided in a Construction Environmental Management Plan (CEMP), conditioned below.

The Biodiversity Net Gain (BNG) Assessment (Avondale Ecology, August 2023) calculates a 22.31% gain in area habitat units. This is supported. A Biodiversity Net Gain Landscape Management Plan has been submitted (Avondale Ecology, September 2023) which identifies management requirements

Development Control Committee A – 24 January 2024

Application No. 23/03423/FB : Filwood Park Playing Fields Creswicke Road Bristol BS4 1UA

on the site for the BNG calculation to be achieved and outlines an appropriate work schedule. This is supported.'

BCC Pollution Control has commented as follows:-

'Whilst it is unlikely that all potential noise issues can be eliminated at such an accessible community use I do feel that the measures now proposed in the management plan show that through the use of CCTV, Parks Management and the Police that any noise or anti-social behaviour issues can be suitably dealt with particularly during the evening/night time when most likely to cause disturbance or distress to nearby residents.

I also feel it has to be noted that some people may or could use the MUGA in an inconsiderate manner the majority of users are unlikely to do so with the MUGA hopefully providing other social and health benefits.'

Refer to Key Issue B for full comments.

Sport England has commented as follows:-

'Sport England raises no objection to this application as it is considered to meet exception 5 of our Playing Fields Policy and to accord with Paragraph 99 of the National Planning Policy Framework (NPPF)' - see Key Issue F for full comments.

BCC Transport Development Management has commented as follows:-

'TDM are satisfied the applicant has provided sufficient information to address the concerns of TDM.

The general arrangements have been prepared by City Engineering in BCC Highways which adheres to the appropriate guidance.

No objections are raised in terms of access, transport or highway safety.'

Refer to Key Issue D for full comments.

BCC Contaminated Land Environmental Protection has commented as follows:-

'The applicants need to demonstrate the proposed application is suitable for use, there is a wealth of information available for the adjacent housing development site which may prove useful in informing any such assessment.

A minimum of a phase 1 desk study looking into contamination must be submitted to the local planning authority and where deemed necessary a phase 2 intrusive investigation shall take place.

This should be secured via condition. If any information is already prepared submission prior to determination is encouraged to reduce the burden of pre-commencement conditions.'

RELEVANT POLICIES

National Planning Policy Framework – September 2023

Bristol Local Plan comprising Core Strategy (Adopted June 2011), Site Allocations and Development Management Policies (Adopted July 2014) and (as appropriate) the Bristol Central Area Plan (Adopted March 2015) and (as appropriate) the Old Market Quarter Neighbourhood Development Plan 2016 and Lawrence Weston Neighbourhood Development Plan 2017 and the Hengrove and Whitchurch Park Neighbourhood Development Plan 2019.

Development Control Committee A – 24 January 2024**Application No. 23/03423/FB : Filwood Park Playing Fields Creswicke Road Bristol BS4 1UA**

In determining this application, the Local Planning Authority has had regard to all relevant policies of the Bristol Local Plan and relevant guidance.

KEY ISSUES**(A) PRINCIPLE OF DEVELOPMENT***Need/Justification*

The supporting Planning Statement sets out the proposed MUGA is required to replace an existing facility at Filwood Broadway which is being decommissioned, with the site allocated for Business, Retail and Housing within the Bristol Local Plan Site Allocation and Development Management Policies (Policy SA1). This aligns with the Filwood Broadway Framework, which was co-developed by the Council, community and key local stakeholders and identified six key priority change projects, one of which being the former Filwood Swimming Pool site which contains the existing MUGA. The proposed new MUGA will be funded by the Council and Filwood's Levelling Up Fund investment.

It is evident that the existing MUGA at Filwood Broadway is not fit for purpose as it is only suitable for a limited number of sports, including football and basketball. The proposed new facility aims to tackle this by increasing the number of sports that can be played, whilst providing additional facilities such as seating areas and fitness equipment.

It is proposed that the new MUGA is constructed to combat both the loss of the existing facilities at Filwood Broadway and the loss of MUGA's in the wider Filwood area, where three have been removed in recent years, including Broadplain MUGA, Airport Road MUGA and Salcombe Road MUGA.

Bristol City Council's Playing Pitch Strategy aims to include development of a network of multi-use games areas for informal and organised sport at 1km intervals. The proposed new MUGA location is 130m away from the existing games area, ensuring that users are not required to travel considerable distances to reach the new facility. This is particularly important for younger users who may be travelling to the MUGA on their own. In accordance with Council's Playing Pitch Strategy, the proposed MUGA location will ensure that MUGAs remain at 1km intervals. The proposed MUGA will also be located within the existing activity and leisure space of Filwood Playing Fields and will therefore complement the sporting activity within the area.

Given the above, the Local Planning Authority is satisfied that there is a need for the facility in the local area.

Discounted Locations

The applicant has provided evidence which indicates that a number of alternative sites were considered for the MUGA, and the reasons why they were discounted.

One location off Gerard Close was considered, however as it was 650 metres from the existing facility this was considered too far for existing residents to walk to access the facility. This location was also 400m from the new South Bristol Youth Zone development, which includes a MUGA facility meaning that both facilities would be in close proximity to one another and serving the same area of the community, whilst leaving a gap in provision closer to the neighbourhood centre of Filwood Broadway where the existing MUGA is located.

A potential location within the Mendip Broadwalk Football Club car park was considered, however the Football Club would not agree to this, as it would prohibit the club's ability to grow into the higher leagues or develop in the future, and potentially cause wider parking issues in the residential areas during football events.

Development Control Committee A – 24 January 2024**Application No. 23/03423/FB : Filwood Park Playing Fields Creswicke Road Bristol BS4 1UA**

One location as suggested by Sport England was considered, however this is within the privately owned Filwood Park and therefore the land is not within public ownership (meaning the Council would be unable to develop it). This location would also be closer to Manning Road and neighbouring properties than the proposed location. Filwood Park residents would therefore not agree to a MUGA on this part of their land due to the additional noise, disturbance and maintenance burden this would produce.

It is recognised that some objections to the application have requested whether the MUGA can be moved further south to an unused area of land between the Community Hub and sports pitch. This location was considered by the applicant, however it was concluded that the location has reduced visibility as the MUGA would sit in a dip and be partially hidden by the Community Hub, therefore causing issues in terms of safety and security. This location would also cause difficulties in achieving maintenance vehicle access to the site. A potential longer maintenance vehicle access route which causes additional losses of green space and habitat disruption, difficulties in achieving Biodiversity Net Gain and significant cost increases. This location is also not as accessible as the proposed MUGA, due to the level changes on the Filwood Park land (not in ownership of the applicant).

Given the above, the Local Planning Authority recognises that alternative locations have been considered and is satisfied for the reasoning why they have not been selected.

Community Use

Core Strategy Policy BCS12 sets out the general approach to the protection of community facilities. This policy states that community facilities should be located where there is a choice of travel options and should be accessible to all members of the community and where possible community facilities should be located within existing centres. Existing community facilities should in addition be retained, unless it can be demonstrated that there is no longer a need to retain the use or where alternative provision is made.

Policy DM5 in the Site Allocations and Development Management Policies sets out that the term community facilities is wide-ranging and can include education establishments, health and social care facilities and sport and recreation facilities. It may also include other uses whose primary function is commercial but perform a social or community role i.e. sport, recreational and leisure facilities. Policy DM5 states that proposals involving the loss of community facilities land or buildings will not be permitted unless it is demonstrated that:

- i. The loss of the existing community use would not create, or add to, a shortfall in the provision or quality of such uses within the locality or, where the use has ceased, that there is no need or demand for any other suitable community facility that is willing or able to make use of the building(s) or land; or
- ii. The building or land is no longer suitable to accommodate the current community use and cannot be retained or sensitively adapted to accommodate other community facilities; or
- iii. The community facility can be fully retained, enhanced or reinstated as part of any redevelopment of the building or land; or
- iv. Appropriate replacement community facilities are provided in a suitable alternative location.

It is recognised that the existing community use which forms part of the site (i.e. Mendip Broadwalk Football pitch) will be retained which is welcomed. This development doesn't seek to remove any existing community facilities from the site or wider area.

It is however noted that the existing MUGA at Filwood Broadway is due to be decommissioned to enable new housing development, with the site allocated for Business, Retail and Housing under Policy SA1 within the Site Allocations and Development Management Policies (2014). The

Development Control Committee A – 24 January 2024**Application No. 23/03423/FB : Filwood Park Playing Fields Creswicke Road Bristol BS4 1UA**

redevelopment of the allocated site would result in the loss of the existing MUGA; the current application seeks to replace and enhance these facilities in a suitable alternative location. The location is sustainable, in very close proximity to the existing MUGA (130 metres away) and the Filwood Broadway Local Centre which is approximately 100 metres to the north. The site is also considered to be accessible to all members of the existing community, with accessible pathways and entrances included. The proposed location of the new MUGA is therefore considered acceptable, and the provision of these facilities to the local area and community are welcomed.

Important Open Space

The application site is located in an area of Designated Important Open Space as defined within the Policies Map associated within the Council's Site Allocations and Development Management Policies Local Plan (2014). Policy DM17 in this document states that development on part, or all of an important open space as designated will not be permitted unless the development is ancillary to the open space use. Policy BCS9 of the Bristol Development Framework Core Strategy (2011) is also applicable, and states that the integrity and connectivity of the strategic green infrastructure network should be maintained, protected and enhanced. Open spaces which are important for recreation, leisure and community, townscape and landscape quality and visual amenity should be protected.

In this specific instance the open space is considered to be important for leisure and community quality, being designated sports pitches and playing field. The overall development will maintain the use of the open space for community use and leisure use and will result in no reduction to size or number of the exist sports pitches. Whilst new structures are proposed in the form of the MUGA, fencing, floodlighting, pathways, seating and exercise equipment this will be ancillary to the wider open space sport/recreation use which will remain the primary function of the site. Whilst the new MUGA and pathways will result in the loss of some existing grass areas the open aspect of the site will broadly be maintained despite the introduction of fencing and other ancillary development as referenced above. Further, the proposed new facilities would fall under the same use class as the existing, being sport and leisure based in nature, which would provide a supporting role of benefit to the ongoing use/function of the open space as playing fields. As such, it is considered that the development would not result in a harmful loss of important open space in this instance. The application is subsequently considered acceptable on this basis.

(B) WOULD THE PROPOSAL HARM THE AMENITY OF NEARBY OCCUPIERS?

Policy BCS23 in the Bristol Core Strategy (2011) states that the locating of development should take account of the impact of the proposed development on the viability of existing surrounding uses by reason of its sensitivity to noise pollution. This policy further states that development should be sited and designed in a way as to avoid adversely impacting upon the environmental amenity or biodiversity of the surrounding area by reason of light pollution. Policy DM35 in the Site Allocations and Development Management Policies (2014) states that any scheme which will have an unacceptable impact on environmental amenity by reason of noise will be expected to provide an appropriate scheme of mitigation.

Policy DM33 in the Site Allocations and Development Management Policies (2014) states that development which has the potential for an unacceptable impact on environmental amenity by reason of pollution will be expected to provide an appropriate scheme of mitigation. This policy further states in the supporting text that light pollution occurs when the night sky, important views or other properties close to development sites become unduly lit by excessive or poorly directed lighting. Light pollution can be mitigated by reducing the overall levels of lighting and ensuring that light is directed away from the sky and nearby light-sensitive development such as housing.

Development Control Committee A – 24 January 2024**Application No. 23/03423/FB : Filwood Park Playing Fields Creswicke Road Bristol BS4 1UA**

The existing site is in use as playing fields and pitches with floodlighting, which are used on a regular basis, both during the week and at weekends. It is recognised however that the new MUGA will be located on an area of land to the east of the existing playing fields which is currently not used for sport/recreation activities.

The closest properties to the proposed MUGA are located at Manning Road, the boundary of these properties being located approximately 32 metres to the east at the closest point. The properties themselves along Manning Road are approximately 36 metres away from the proposed MUGA at the closest point. Further residential properties exist at Creswicke Road to the north, with the closest property boundary located approximately 35.5m away from the site. The properties themselves at Creswicke Road are approximately 50 metres away.

The main consideration in terms of the impact on amenity of local residents is whether the use of the proposed MUGA is likely to result in increased levels of noise/disturbance or light pollution (though flood lighting) compared to the existing situation.

Flood lighting is proposed to the new MUGA in the form of 4.no eight metre high column lights arranged to the four corners of the court. In terms of light pollution, the application is supported by a Floodlighting Impact Assessment and LUX plan to demonstrate the luminance levels and light spill from the proposed floodlights. This information shows that the proposed lighting system has been designed to meet the specific lighting requirements for recreational play of large ball sports, however no harm will be caused to the amenity of any surrounding neighbouring properties by virtue of light pollution. This is primarily due to the limited height of the floodlights, separation distance with neighbours and luminance levels. To ensure that the use of the lights is limited as much as possible the floodlights will also be switched off at 8pm, and after 6pm they will be on an activation button where they will only be switched on if activated manually. The hours of use of the floodlighting is consistent with that of the adjacent sports pitches, which also have flood lighting. Given the above, the Council's Pollution Control Team raised no objections to the proposed floodlights with regards to impact on neighbours.

With regards to noise pollution, it is accepted that the nature of the development would result in increased activity at the site and the playing of sports/activities which could be noisy. It is further recognised that a number of objections from surrounding neighbour properties have raised noise and disturbance as a concern.

The MUGA however adheres to Fields in Trust guidance which states that there should be a 30-metre minimum separation between any MUGA activity zone and the boundary of the nearest property containing a dwelling. As noted above, the boundary of no residential property is located within 30 metres of the proposed MUGA activity zone. Fields in Trust is the operating name of the National Playing Fields Association (NPFA) which protects parks and green spaces and promotes the cause of accessible spaces for play, sports and recreation in British cities and towns.

A noise impact assessment has also been submitted to support the application. The assessment considers the impact of noise from the MUGA during sports type uses such as basketball, football etc during times that the floodlights will be on (originally this was proposed to be up to 10pm in the evening). During these times, with these activities, the assessment predicts that noise from the MUGA would be above Sport England guidance levels and 6 dB higher than the background noise level between 21.00 and 22.00. At these sort of levels, the Council's Pollution Control Team confirmed that there would likely be an impact on neighbours, despite the relatively considerable separation distance between the MUGA and neighbouring properties.

An earlier finish time for the floodlights was therefore considered necessary; the applicant agreed to limit the use of the floodlights so that they will be switched off at 8pm, and after 6pm they will be on an activation button where they will only be switched on if activated manually. The Council's Pollution Control Team confirmed that this would ensure that noise and disturbance will be minimised during

Development Control Committee A – 24 January 2024**Application No. 23/03423/FB : Filwood Park Playing Fields Creswicke Road Bristol BS4 1UA**

the quieter periods of the day, during winter months (between September and April when it gets dark before 8pm).

It is noted that the use of the MUGA (and associated noise issues) may extend into the evening during the summer months (between May and August where it stays light for longer) however there is no effective way to manage this aside from locking the MUGA at 8pm each night. This however is not considered to be appropriate or practical for the reasons set out in Key Issue J (see below). The MUGA however has been designed so that it can be secured at night, with gates that could be locked in the future by the Council's Parks Team if necessary, should noise, disturbance and anti-social behaviour issues become an apparent problem when post development monitoring begins. This is set out in the Management Statement, compliance of which is secured via condition.

Overall there is no way to completely eliminate the risk of noise and disturbance arising from the proposed MUGA. The nature of the facility is such that noisy activities may arise; both from 'typical' uses associated with the MUGA (sports and recreation) but also through other uses, including anti-social behaviour. However, the LPA is satisfied that efforts have been made to limit anti-social behaviour (refer to Key Issue J) and limit the impact of noise on surrounding residential properties as much as possible. The MUGA activity zone will be sited at least 30 metres away from all neighbours, floodlighting will be switched off at 8pm and the facility has been designed so that it can be secured at night, with gates that could be locked in the future by the Council's Parks Team if necessary, should noise/disturbance become an apparent problem. Any noise and disturbance arising from the use of the MUGA for sports/recreation deemed to be harmful would likely only occur for a third of the year, in the evening during the summer months, between May and August where it stays light for longer. Whilst there is potential for further noise impacts arising from other uses of the MUGA, including some people using the MUGA in an inconsiderate manner at night time due to it being an unsecured facility, overall it is the view of the LPA that this will be infrequent and measures to prevent/limit anti-social behaviour issues have been considered at the design stage (refer to Key Issue J).

Given the above, on balance the proposal is not considered harmful enough to the amenity of surrounding residential properties with regards to noise and disturbance to warrant refusal when weighed in the balance with the significant community, recreation and health benefits associated with the new MUGA facility.

Initially a secondary pedestrian route linking the MUGA to the east (Manning Road) was included within the proposals however following concerns raised by local residents this was removed from the scheme entirely by the applicant.

(C) APPEARANCE, DESIGN AND CHARACTER

Policy BCS21 in the Bristol Core Strategy (2011) advocates that new development should deliver high quality urban design and safeguard the amenity of existing development. Site Allocations and Development Management (2014) Policy DM27 also states that the layout, form, pattern and arrangement of streets, buildings and landscapes should contribute towards to creation of quality urban space and that the height, scale and massing of development should be appropriate to the immediate context, site constraints, character of adjoining streets and spaces and setting.

Flood lighting is proposed to the MUGA in the form of 4. no eight metre high column lights arranged to the four corners of the ball court. CCTV will be attached to the floodlights. The proposed columns would be unobtrusive given the limited bulk and massing of the structures and will appear in keeping with the surrounding context (sports fields). They will further be a limited height (8 metres) which will ensure they will not be overly visible from long distance views, nor will they appear prominent or incongruous additions within the local townscape.

Development Control Committee A – 24 January 2024**Application No. 23/03423/FB : Filwood Park Playing Fields Creswicke Road Bristol BS4 1UA**

The proposed MUGA will be surrounded by a 4 metre high ball court, mesh fencing system. This element of the scheme represents the most intense form of development, by virtue of its height and general design. However, the necessity for such fencing around MUGAs and ball courts is recognised, and the fencing will retain some visual permeability through its mesh design to ensure it doesn't appear an overly solid or prominent addition to the open space or wider area. The MUGA and fencing will further be sited away from the public realm, with the site adjacent to existing established sports pitches. This will minimise its impact on the site's openness and will limit the visibility and prominence when viewed from the surrounding public realm and streets.

The associated ancillary structures and equipment (i.e. seating, exercise equipment) will be in keeping with the immediate context and character of the site (sports pitches). Further detail of these elements is secure via condition to ensure it is of a scale and design which will not appear overly prominent with regards to the surrounding townscape.

A 4 metre wide bitmac path is proposed to surround the court. A 3m wide access route from Creswicke Road will ensure that the MUGA can be accessed by pedestrians and serviced and maintained by the Bristol Council Parks team. The access route will be constructed using heavy duty permeable plastic paving grids. It is accepted that the MUGA and new access routes will result in the loss of soft landscaping and green infrastructure. This is not ideal, however following consultation the Council's City Design Group and Nature Conservation Officer confirmed that the soft landscaping to be removed does not hold significant visual amenity value, being primarily long grass and shrubs not of a significant size. Further, the amount of soft landscaping removed would only equate to a very small proportion of the total soft landscaping within the open space. The boundary scrub at the site will be retained and there will be new habitat management and new tree planting, which enable Biodiversity Net Gain to be achieved. The loss as a whole would subsequently not impact significantly or detrimentally enough upon the existing character of the open space or wider area to warrant refusal.

The overall design, layout and scale of development is therefore considered acceptable in the context of the site and surrounding area and is recommended for approval on this basis, subject to conditions.

(D) DOES THE PROPOSAL ADEQUATELY ADDRESS HIGHWAY SAFETY ISSUES?

Policy BCS10 in the Bristol Core Strategy (2011) states that developments should be designed and located to ensure the provision of safe streets and reduce as far as possible the negative impacts of vehicles such as excessive volumes, fumes and noise. Policy DM23 in the Site Allocations and Development Management Policies (2014) in addition states that development should not give rise to unacceptable traffic conditions. Examples of unacceptable traffic conditions referred to in the policy include the introduction of traffic of excessive volume, size or weight on to unsuitable highways/or in to residential or other environmentally sensitive areas. This could result in high levels of transport noise and disturbance, a decrease in air quality and unsafe conditions both on the highway and for pedestrians.

The application has been considered by the Council's Transport Development Management Team (TDM).

The application originally sought approval for two access routes for maintenance purposes, however one route to the east via Manning Road was removed during the course of the application. The Manning Road access route was subject to consultation and approval with Filwood Park residents and their management company. Following the consultation exercise, the management company advised the applicant that the access route across their land at Filwood Park would not be supported. The access proposal plans were therefore amended to reflect this advice, and revised plans submitted. The access route is now only proposed from Creswicke Road. This route will be fully secured and locked via a gate, utilising the Bristol Parks team locking system and will be locked for vehicles at all times except when cleaning and maintenance is being carried out. Pedestrian access will be obtained

Development Control Committee A – 24 January 2024**Application No. 23/03423/FB : Filwood Park Playing Fields Creswicke Road Bristol BS4 1UA**

through a chicane gate, therefore prohibiting unauthorised private vehicle access. TDM confirmed that the access route, including for maintenance purposes, is acceptable and will result in no highway safety or transport issues.

It is recognised that pedestrians may still try and access the MUGA directly from the east via Manning Road. There is currently an existing fence and a considerable scrub / shrubbery buffer to the east of the MUGA which will be retained as a defensible boundary. Whilst this may not completely restrict access via Manning Road it will be a suitable deterrent; a larger, higher or more restrictive boundary treatment would not be appropriate in this location from a landscape, ecology and visual perspective.

Emergency vehicles will be able to access Filwood Fields playing pitches via the football club car park. To reach the MUGA, these vehicles will be able to drive down the maintenance access route, via the football club entrance. Alternatively, it is also possible to drive emergency vehicles from Manning Road across the path/grass towards the rear of the Filwood Park Hub building, as it is only 10m away from the MUGA and within reach of fire hoses. TDM raised no concerns or objections in relation to the emergency access arrangements.

There will be a loss of 1-2 parking spaces to enable maintenance access from Creswicke Road. The carriageway will be reconstructed in the location of a new vehicle access kerb and the footway will also be reconstructed to accommodate a dropped kerb. TDM raised no objections to the limited loss of on street parking spaces given the context, however noted that as the application will have some impact on the current highway a financial contribution of £6,310 is required to cover the cost of any Traffic Regulation Order. This will be secured via a Memorandum of Understanding between Council departments.

The applicant has confirmed that the maintenance access route will not be Adopted Highway, and following a request from TDM vehicle visibility splay measuring 2.4m x 25m from the proposed vehicle accessway at Creswick Road has been provided. Sheffield stands for bicycles have also been included, following a request from TDM.

A construction management plan is secured via condition, to ensure the development has no impact on the existing highway network and neighbouring properties during the construction period.

Following the submission of further information and revised plans TDM confirmed that they have not objections to the proposal with regards to the access or highway safety issues. The application is therefore recommended for approval on this basis, subject to conditions.

(E) NATURE CONSERVATION

The proposal is within a locally identified Wildlife Corridor Site (Bonnington Walk Playing Fields). Policy DM19 in the Site Allocations and Development Management Policies (2014) seeks to protect habitat, features and species which contribute to nature conservation, and developments are expected to be informed by appropriate surveys. This policy further states that development which would have a harmful impact on the connectivity and function of sites in Wildlife Corridors will only be permitted where the loss in connectivity, or function, of an existing Wildlife Corridor is mitigated in line with the following hierarchy:

- a. Creation of a new wildlife corridor within the development site;
- b. Enhancement of an existing corridor or creation of a new corridor off-site to maintain the connectivity of the Bristol Wildlife Network.'

Development Control Committee A – 24 January 2024**Application No. 23/03423/FB : Filwood Park Playing Fields Creswicke Road Bristol BS4 1UA**

This policy further states that development should integrate existing wildlife corridors. Where this is not practicable it should provide suitable mitigation in the form of on-site, functional Wildlife Corridor(s). Development should also provide mitigation for any habitats, species or features of value associated with the Wildlife Corridors, where they are harmed or lost. This should take place on the development site wherever possible.

The application has been considered by the Council's Nature Conservation Team, who confirmed that the site is located in an urbanised area on a recreational (sports) site and is directly adjacent to the Airport Road Site of Nature Conservation Interest (SNCI). The site is not within the West of England Nature Partnership (WENP) Nature Recovery Network. It is not considered this development will have an impact to the SNCI site.

The application is supported by a Preliminary Ecological Appraisal (PEA) which appropriately describes the ecological features of the site and any mitigation required. The submitted Reptile Survey Report identifies mitigation and avoidance measures that must be in place to avoid the risk of killing/injury of reptiles present on site. Evidence that these are in place must be provided in a Construction Environmental Management Plan (CEMP), which is secured via condition.

Following Case Officer advice further information was provided with regards to light levels and the potential impact on bats. Following review of this information the Council's Nature Conservation Officer confirmed that lux (light) levels will be low enough beyond the 10m 5lux mark of the lighting plan, where some of the linear features slightly more attractive to bats are. The timer will also prevent excessive lighting disturbance to nocturnal animals during their usual foraging/commuting periods, and recommendations in the ILP guidance for bats have been followed. As such, the Council's Nature Conservation Officer confirmed that the development will cause no harm to existing nocturnal animals and bats.

The application is supported by a Biodiversity Net Gain (BNG) Assessment which calculates a 22.31% gain in area habitat units. The majority of the site comprises infrequently cut species-poor semi-improved grassland; the biodiversity net gain will be achieved by the creation of new mixed native scrub planting areas, species-rich neutral grassland, the reseeded of existing modified grassland with a more diverse seed mix, maintaining existing long tussocky grassland, the planting of at least two standard trees, the creation of habitat piles for reptiles and other species and the installation of hedgehog connectivity measures at the site boundaries. This is supported. A Biodiversity Net Gain Landscape Management Plan has also been submitted which identifies management requirements on the site for the BNG calculation to be achieved and outlines an appropriate work schedule. This is also supported.

The application is therefore considered acceptable on ecology grounds, subject to conditions requiring the submission of a CEMP as noted above.

(F) DO THE PROPOSALS RAISE ANY SPORTS AND LEISURE PROVISION ISSUES?

The proposal prejudices the use of land being used as a playing field in the last five years, as defined in The Town and Country Planning (Development Management Procedure) (England) Order 2015 (Statutory Instrument 2015 No. 595). Consultation with Sport England is therefore a statutory requirement.

Following consultation, Sport England commented that MUGAs can be an important facility for informal physical activity and formal recreational sport. Sport England therefore recognised that the proposal would improve the local area but raised concern that the siting of the facility may affect the future of the adjacent playing pitch that has sports lighting already in place.

Development Control Committee A – 24 January 2024

Application No. 23/03423/FB : Filwood Park Playing Fields Creswicke Road Bristol BS4 1UA

Sport England therefore queried whether the MUGA could be located in an alternative position away from the adjacent sports pitch, however this was discounted by the applicant for the reasons set out in Key Issue A.

Further information was therefore requested to demonstrate that the development of the MUGA adjacent to the sports pitch would not prejudice the future expansion of Mendip Broadwalk FC (the first team of which has aspirations to progress through the football pyramid, which would require additional stadia requirements).

The applicant subsequently provided this information, and engaged directly with the adjacent sports club and Football Foundation to discuss the proposals and provide assurance that the MUGA development can be undertaken without impacting the future expansion of Mendip Broadwalk FC.

Sport England therefore raised no objections to the application, confirming that it meets exception 5 of their Playing Fields Policy and to accord with Paragraph 99 of the National Planning Policy Framework (NPPF), in that the proposed development is for an indoor or outdoor facility for sport, the provision of which would be of sufficient benefit to the development of sport as to outweigh the detriment caused by the loss, or prejudice to the use, of the area of playing field.

(G) FLOOD RISK

Bristol Core Strategy (2011) Policy BCS16 states that all development will also be expected to incorporate water management measures to reduce surface water run-off and ensure that it does not increase flood risks elsewhere. This should include the use of sustainable drainage systems (SUDS).

The Council's Flood Risk Team have reviewed the application and confirmed that the flood risk posed to the site is deemed as relatively low from all sources of flooding. A suitable means of drainage provision has been identified to serve the development. This includes porous macadam surfacing, French drains and soakaway trenches. The infiltration potential appears good from the ground investigation conducted and so the proposed infiltrating SuDS methods should operate effectively. The regular maintenance schedule for the site will also help continue their ongoing functioning. The application is therefore considered acceptable on flood risk grounds in principle, however it is noted that the final drainage design will be confirmed once geo-technical survey is completed. A further detailed drainage scheme is therefore secured via condition.

(H) DO THE PROPOSALS ADEQUATELY ADDRESS ANY CONTAMINATION ISSUES RELATING TO THE SITE?

Policy DM34 in the Site Allocations and Development Management Policies (2014) states that new development should demonstrate that:

- i. Any existing contamination of the land will be addressed by appropriate mitigation measures to ensure that the site is suitable for the proposed use and that there is no unacceptable risk of pollution within the site or in the surrounding area; and
- ii. The proposed development will not cause the land to become contaminated, to the detriment of future use

Following consultation, the Council's Contaminated Land raised no objections to the application in principle, however noted that it must be demonstrated that the proposal is suitable for use in terms of land contamination. A minimum of a phase 1 desk study looking into contamination is required, and where deemed necessary a phase 2 intrusive investigation should take place. This is secured via condition.

Development Control Committee A – 24 January 2024**Application No. 23/03423/FB : Filwood Park Playing Fields Creswicke Road Bristol BS4 1UA****(I) IMPACT ON TREES**

Policy BCS9 in the Bristol Core Strategy (2011) states that the integrity and connectivity of the strategic green infrastructure network should be maintained, protected and enhanced. Individual green assets should be retained wherever possible and that development should incorporate new or enhanced green infrastructure of an appropriate type, standard and size. Policy DM17 in the Site Allocations and Development Management Policies (2014) states that all new development should integrate important existing trees. Where tree loss or damage is essential to allow for appropriate development, replacement trees of an appropriate species should be provided in accordance with the tree compensation standard. Policy DM15 in the same document states that green infrastructure provision facilitates a positive effect on people's health by providing space and opportunities for sport, play, and social interaction. The provision of additional and/or improved management of existing trees will be expected as part of the landscape treatment of new development.

The Council's Arboricultural Officer confirmed that there are no substantial trees located in close enough proximity to the proposed development to be impacted upon by the proposals. The boundary scrub at the site will be retained and there will be new habitat management and new tree planting which is welcomed.

(J) SAFETY AND SECURITY

Paragraphs 92, 97 and 130 of the National Planning Policy Framework (2023) require crime and disorder and fear of crime to be considered in the design stage of a development. Other paragraphs such as 8, 97, 106, 108, 110, 112 and 119 also require the creation of safe environments within the context of the appropriate section.

Bristol Core Strategy (2011) states that one of the overarching issues for ensuring a sustainable future is reducing the opportunity for crime. Site Allocations and Development Management Policy DM28 (2014) states that development should create or contribute to a safe, attractive, high quality, inclusive and legible public realm that contributes positively to local character and identity and encourages appropriate levels of activity and social interaction. Section 4 adds that development will be expected to reduce crime and fear of crime by creating a well-surveyed public realm that is well managed and cared for.

The application has been considered by the Avon and Somerset Constabulary Designing Out Crime Officer (DOCO) who has a responsibility for Crime Prevention Through Environmental Design (CPTED) projects within the Bristol area. In assessment of the application, the DOCO has considered guidance on play areas as contained in the document Secured by Design Homes 2023.

A number of objections have been raised by surrounding residents regarding the development increasing anti-social behaviour issues (ASB) and resulting in crime, and it is recognised based on local crime data that ASB forms the highest incident count in the area.

Initial concerns were raised by the DOCO regarding the scope and purpose of the CCTV system. Further information was therefore provided by the applicant, including confirmation that the Council's CCTV Operations Centre will be providing the monitoring. On this basis, the DOCO confirmed they are satisfied that evidential quality images will be captured by the CCTV which could be used for effective prosecution. The CCTV will therefore act as a crime/ASB deterrent and will be of a suitable quality to give investigators reasonable lines of enquiries to identify and deal with offenders of both crime and ASB. The Local Police highlighted a recent nearby example outside of Dame Emily Park where an incident captured on Council CCTV enabled the police to issue multiple notices and warnings to those involved quelling their behaviour. The Police noted that without the CCTV the behaviour would likely continue without them being able to identify and deal with offenders.

Development Control Committee A – 24 January 2024**Application No. 23/03423/FB : Filwood Park Playing Fields Creswicke Road Bristol BS4 1UA**

It is proposed that the MUGA will remain open and accessible 24/7. It is recognised that this will increase the risk of crime and ASB (including vandalism and graffiti that occurs after dark). Discussions were held between the LPA and applicant regarding the potential to lock the MUGA overnight. It was however determined, following further discussion with the Council's Parks Team (who will be responsible for the management and maintenance of the MUGA) that implementing an overnight locking service from Bristol Workplace can be unreliable and may not always be practical. If the MUGA was in use there would also be difficulties and disadvantages to it being locked, as users would need to be removed first. It was also considered that locking the MUGA failed to accord with the general purpose and benefit of the development, offering unrestricted access to sporting facilities to all people, at all times. As such, on balance it was not considered necessary to secure the locking of the MUGA overnight. The MUGA however has been designed so that it can be secured at night, with gates that could be locked in the future by the Council's Parks Team if necessary, should ASB and crime become an apparent problem when post development monitoring begins (including CCTV). This is set out in the Management Statement, compliance of which is secured via condition.

Pedestrians will be able to reach the access route via a chicane gate, which is separate from the locked maintenance gate. The chicane gate will ensure that unauthorised vehicles (e.g. motorbikes) are unable to access the site.

Initially a secondary pedestrian access route linking the MUGA to the east (Manning Road) was included within the proposals however following concerns raised by local residents this was removed from the scheme entirely by the applicant. A secondary emergency route for pedestrians however will be available to the south. The inclusion of only one dedicated access to the MUGA (from the north via Creswicke Road) is not ideal, however it is recognised that the secondary route (as initially proposed) was removed following safety and security concerns raised by local residents. The northern access route will include no lighting. It is noted that this could result in safety and security issues, however it is unlikely that the route will be used frequently during night time or darkness hours given that the MUGA floodlighting will not operate after 8pm. Further illuminating the route with lighting could result in further amenity issues for properties to the north along Creswicke Road with regards to light pollution. The DOCO was consulted on the revised access arrangement and raised no objections/concerns. Overall the dedicated access from the north, and emergency access to the south are considered sufficient to serve the MUGA from a safety and security perspective. It is recognised that people may still try and access the MUGA directly from the east via Manning Road. There is currently an existing fence and a considerable scrub / shrubbery buffer to the east of the MUGA which will be retained as a defensible boundary. Whilst this may not completely restrict access via Manning Road it will be a suitable deterrent; a larger, higher or more restrictive boundary treatment would not be appropriate in this location from a landscape, ecology and visual perspective.

Ultimately it is not possible to eliminate the risk of crime completely, nor is there any evidence which could be provided to demonstrate that the development will not cause issues. Given the above however, the LPA is satisfied that the proposal is policy compliant in that crime and disorder and fear of crime has been considered in the design stage of the development. The use of CCTV, the facility being designed so that it could be secured at night, features in place to prevent unauthorised vehicular access and the commitment to regular maintenance and monitoring by the Council's Parks Team (as detailed in the approved Management Statement) will help reduce the opportunity for crime arising from the proposal and demonstrate that crime has been considered. The application is therefore considered acceptable on this basis.

(K) ARCHAEOLOGY

Following consultation, the Council's Archaeology Officer noted that the area of the proposed development is known to have been occupied during the Romano-British period. Previous archaeological work in the vicinity has recorded well preserved evidence of a substantial agricultural community during the late Iron Age to Roman era.

Development Control Committee A – 24 January 2024

Application No. 23/03423/FB : Filwood Park Playing Fields Creswicke Road Bristol BS4 1UA

The site itself has been subject to previous non-intrusive geophysical surveys that have suggested that there is limited archaeological evidence surviving beneath the playing field, possibly as a result of previous landscaping and drainage works. However, deeper archaeological features may be present. Therefore an assessment of the potential impact to the archaeological significance on this site was requested.

Based on the submitted information and evaluation report referenced, the Council's Archaeology Officer confirmed that there is unlikely to be any impact to archaeological significance posed by this scheme. As such, the application is considered acceptable on this basis and there are no further archaeological requirements.

(L) PUBLIC HEALTH

Policy DM14 (The Health Impacts of Development) of the Site Allocations and Development Management Policies (2014) outlines that development should contribute to reducing the causes of ill health, improving health and reducing health inequalities within the city through promoting and enabling healthy lifestyles as the normal, easy choice.

By means of providing the new, enhanced facilities to the local area, with potential to play a range of sports and activities, as well as fitness equipment, the proposal would result in a wide ranging physical and mental health benefits. This would contribute to objectives of reducing ill health and improving public health within Bristol.

CONCLUSION

Following the submission of further detail the application is considered acceptable and is recommended for approval, subject to conditions.

COMMUNITY INFRASTRUCTURE LEVY

How much Community Infrastructure Levy (CIL) will this development be required to pay?

Development of less than 100 square metres of new build that does not result in the creation of a new dwelling; development of buildings that people do not normally go into, and conversions of buildings in lawful use, are exempt from CIL. This application falls into one of these categories and therefore no CIL is payable.

EQUALITY ASSESSMENT

During the determination of this application due regard has been given to the impact of this scheme in relation to the Equality Act 2010 in terms of its impact upon key equalities protected characteristics. These characteristics are age, disability, gender reassignment, marriage and civil partnership, pregnancy and maternity, race, religion or belief, sex and sexual orientation. There is no indication or evidence (including from consultation with relevant groups) that different groups have or would have different needs, experiences, issues and priorities in relation this particular proposed development. Overall, it is considered that this application would not have any significant adverse impact upon different groups or implications for the Equality Act 2010.

Development Control Committee A – 24 January 2024**Application No. 23/03423/FB : Filwood Park Playing Fields Creswicke Road Bristol BS4 1UA****RECOMMENDED GRANT subject to condition(s)****Time limit for commencement of development**

1. Full Planning Permission

The development hereby permitted shall begin before the expiration of three years from the date of this permission.

Reason: As required by Section 91 of the Town and Country Planning Act 1990, as amended by Section 51 of the Planning and Compulsory Purchase Act 2004.

Pre commencement condition(s)

2. Protection of Retained Trees during the Construction Period

No work of any kind shall take place on the site until the protective fences have been erected around the retained trees in the position and to the specification shown on the Tree Protection Plan referenced 22-010 06 Rev A. Once installed photos should be electronically sent to the Local Authority Case Officer, shall be submitted to and approved in writing by the LPA in order that the council may verify that the approved tree protection measures are in place when the work may commence. The approved fences shall be in place before any equipment, machinery or materials are brought on to the site for the purposes of the development and shall be maintained until all equipment, machinery and surplus materials have been removed from the site. Within the fenced area there shall be no scaffolding, no stockpiling of any materials or soil, no machinery or other equipment parked or operated, no traffic over the root system, no changes to the soil level, no excavation of trenches, no site huts, no fires lit, no dumping of toxic chemicals and no retained trees shall be used for winching purposes. If any retained tree is removed, uprooted or destroyed or dies, another tree shall be planted at the same place and that tree shall be of such size and species, and shall be planted at such time, as may be specified in writing by the council.

Under no circumstances should the tree protection be moved during the period of the development and until all works are completed and all materials and machinery are removed. Landscaping works within protected areas is to be agreed with the Local Planning Authority and carried out when all other construction and landscaping works are complete.

Reason: To protect the retained trees from damage during construction, including all ground works and works that may be required by other conditions, and in recognition of the contribution which the retained tree(s) give(s) and will continue to give to the amenity of the area in line with Policy DM17.

3. Construction Management Plan

No development shall take place, including any demolition works, until a construction management plan or construction method statement has been submitted to and approved in writing by the Local Planning Authority. The approved plan/statement shall be adhered to throughout the demolition/construction period. The plan/statement shall provide for:

- o 24 hour emergency contact number;
- o Hours of operation;
- o Parking of vehicle of site operatives and visitors (including measures taken to ensure satisfactory access and movement for existing occupiers of neighbouring properties during construction);
- o Routes for construction traffic;

Development Control Committee A – 24 January 2024**Application No. 23/03423/FB : Filwood Park Playing Fields Creswicke Road Bristol BS4 1UA**

- o Locations for loading/unloading and storage of plant, waste and construction materials;
- o Method of preventing mud being carried onto the highway;
- o Measures to protect vulnerable road users (cyclists and pedestrians)
- o Any necessary temporary traffic management measures;
- o Arrangements for turning vehicles;
- o Arrangements to receive abnormal loads or unusually large vehicles;
- o Methods of communicating the Construction Management Plan to staff, visitors and neighbouring residents and businesses.

Reason: In the interests of safe operation of the adopted highway in the lead into development both during the demolition and construction phase of the development.

4. Site Specific Construction Environmental Management Plan (CEMP)

No development shall take place until a site specific Construction Environmental Management Plan has been submitted to and been approved in writing by the Local Planning Authority. The plan must include measures to comply in full with the recommendations made in the Preliminary Ecological Appraisal (PEA) (Avondale Ecology, August 2023) and the Reptile Survey Report (Avondale Ecology, September 2023), i.e to avoid offences against legally protected and priority species and habitats during construction, including site clearance and demolition. Provision shall be made within the CEMP for the appointment of an Ecological Clerk of Works (ECoW) to undertake site visits and to supervise ecologically sensitive operations.

Where considered to be required by the project ecologist, the CEMP shall be supplemented by a Method Statement for a Preliminary Method of Working (MS-PMW) to avoid accidental harm being caused to any protected, priority or notable habitats or species.

The development shall be carried out in full accordance with the approved details or any amendments agreed in writing by the Local Planning Authority.

Reason: To demonstrate compliance with: the 1981 Wildlife & Countryside Act (as amended); the 1996 Wild Mammals Protection Act; the 2017 Habitats Regulations; the 2006 NERC Act; the 2006 Animal Welfare Act; and the 1992 Protection of Badgers Act.

5. Sustainable Drainage System (SuDS)

No development shall take place until a Sustainable Drainage Strategy and associated detailed design, management and maintenance plan of surface water drainage for the site using SuDS methods has been submitted to and approved in writing by the Local Planning Authority. The approved drainage system shall be implemented in accordance with the approved Sustainable Drainage Strategy prior to the use of the MUGA commencing and maintained thereafter for the lifetime of the development.

Reason: To prevent the increased risk of flooding by ensuring the provision of a satisfactory means of surface water disposal is incorporated into the design and the build and that the principles of sustainable drainage are incorporated into this proposal and maintained for the lifetime of the proposal.

6. Site Characterisation and Risk Assessment

No development shall take place until the works relating to land contamination below are completed:

Development Control Committee A – 24 January 2024**Application No. 23/03423/FB : Filwood Park Playing Fields Creswicke Road Bristol BS4 1UA**

With consideration to human health, controlled waters and the wider environment, the following documents shall be completed (as required) to characterise potential risk to sensitive receptors and submitted to the LPA for approval:

- I. Preliminary Risk Assessment (PRA);
- II. Generic Quantitative Risk Assessment (GQRA);
- III. Detailed Quantitative Risk Assessment (DQRA).

Submission of a PRA is the minimum requirement. DQRA only to be submitted if GQRA findings require it.

The actions required above shall be completed in accordance with the following guidance: Land Contamination Risk Management (Environment Agency, 2023).

Reason: To ensure that risks from land contamination is understood prior to works on site both during the construction phase to the future users of the land and neighbouring land are minimised, together with those to controlled waters, property and ecological systems, and to ensure that the development can be carried out safely without unacceptable risks to workers, neighbours and other offsite receptors

7. Remediation Strategy and Verification Plan

No development shall take place until the works relating to land contamination below are completed:

In accordance with the findings of Site Characterisation & Risk Assessment, documents from the following shall be submitted (as required) to the LPA for approval:

- I. Remedial Options Appraisal;
- II. Remediation Strategy;
- III. Verification Plan.

The actions required above shall be completed in accordance with the following guidance: Land Contamination Risk Management (Environment Agency, 2023).

Reason: To ensure that risks from land contamination is understood prior to works on site both during the construction phase to the future users of the land and neighbouring land are minimised, together with those to controlled waters, property and ecological systems, and to ensure that the development can be carried out safely without unacceptable risks to workers, neighbours and other offsite receptors.

8. Remediation and Verification

The consented development shall not be taken into use until the works relating to land contamination below are completed:

Remediation (if required) shall be carried out in accordance with the approved Remediation Strategy.

A Verification Report must be submitted to the LPA for approval. The Verification Report must include information validating all remediation works carried out; details of imported fill materials (source/quantity/suitability); details of exported fill materials; and details of any unexpected contamination.

Development Control Committee A – 24 January 2024**Application No. 23/03423/FB : Filwood Park Playing Fields Creswicke Road Bristol BS4 1UA**

The actions required above shall be completed in accordance with the following guidance: Land Contamination Risk Management (Environment Agency, 2023).

Reason: To ensure that risks from land contamination both during the construction phase and to the future users of the land and neighbouring land are minimised, together with those to controlled waters, property and ecological systems, and to ensure that the development can be carried out safely without unacceptable risks to workers, neighbours and other offsite receptors.

9. Further details of pedestrian access

No development shall take place until details of the proposed dedicated pedestrian and cycling access to the site have been submitted to and approved in writing by the Local Planning Authority. Prior to occupation the access shall be completed in accordance with the approved plans.

Reason: To ensure safe and adequate pedestrian access to the site.

10. Large scale detail

Prior to the commencement of the relevant part of the works hereby approved drawings to a minimum 1:10 scale (also indicating location, materials, treatments, and finishes) of the following items shall be submitted to and approved in writing by the Local Planning Authority, unless otherwise agreed in writing by the Local Planning Authority.

- (a) Exercise equipment
- (b) Benching and shelter
- (c) All new boundary treatment

The detail thereby approved shall be carried out in accordance with that approval.

Reason: To ensure that the external appearance is satisfactory and that the character and appearance of the area would not be harmed.

Pre occupation condition(s)

11. Unexpected Contamination

The consented development shall not be taken into use until written confirmation is provided to the LPA that unexpected or previously-unidentified contamination was not encountered during the course of development works.

If, during development, unexpected contamination is found to be present on the site, no further works shall be carried out at the affected location until the following are submitted to the LPA for approval:

- I. Risk Assessment (GQRA or DQRA);
- II. Remediation Strategy & Verification Plan;

Remediation (if required) shall be carried out in accordance with the approved Remediation Strategy. Upon completion of works, a Verification Report shall be submitted for approval.

Development Control Committee A – 24 January 2024**Application No. 23/03423/FB : Filwood Park Playing Fields Creswicke Road Bristol BS4 1UA**

The actions required above shall be completed in accordance with the following guidance: Land Contamination Risk Management (Environment Agency, 2023).

Reason: To prevent unacceptable risk to Human Health and Controlled Waters and to prevent pollution of the environment in accordance with the aims and objectives of the National Planning Policy Framework. Where a site is affected by contamination issues, responsibility for securing a safe development rests with the developer and/or landowner.

12. Further details of external lighting provision within the site:

No building or use hereby permitted shall be occupied or use commenced until detailed designs of the following have been submitted to and approved in writing by the Local Planning Authority:

- A system of external lighting in the publicly accessible areas within the site;
- The results of a lighting assessment undertaken in accordance with Guidance Note 1 for the Reduction of Obtrusive Light (2020).

The detail thereby approved shall be carried out in accordance with that approval.

Reason: To minimise the discharge of surface water onto the adopted highway

13. Completion of Vehicular Access - Shown on Approved Plans

No building or use hereby permitted shall be occupied or use commenced until the means of vehicular access has been constructed and completed in accordance with the approved plans and the said means of vehicular access shall thereafter be retained for access purposes only for the lifetime of the development. Any access point opening onto the adopted highway shall include suitable drainage provision within the curtilage of the site, to prevent the discharge of any surface water onto the adopted highway.

Reason: To ensure that the vehicular access point is safe and includes adequate drainage.

14. Installation of vehicle crossover - Shown on Approved Plans

No building or use hereby permitted shall be occupied or use commenced until drop kerbs has been installed at the carriageway edge and a vehicle cross-over constructed across the footway fronting the site in accordance with the approved plans and retained in that form thereafter for the lifetime of the development.

Reason: In the interests of pedestrian safety and accessibility

15. Completion and Maintenance of Cycle Provision - Shown on approved plans

No building or use hereby permitted shall be occupied or the use commenced until the cycle parking provision shown on the approved plans has been completed, and thereafter, be kept free of obstruction and available for the parking of cycles only.

Reason: To ensure the provision and availability of adequate cycle parking.

16. Provision of Vehicular Visibility Splays

No building or use hereby permitted shall be occupied or use commenced until visibility splays 2.4 metres back from the centre line of the access and extending (FILL IN) metres on the nearside carriageway edge shall be provided at all accesses/junctions, as shown on the

Development Control Committee A – 24 January 2024**Application No. 23/03423/FB : Filwood Park Playing Fields Creswicke Road Bristol BS4 1UA**

approved plans. Nothing shall be erected, retained, planted and/or allowed to grow at or above a height of 0.6 metres above the nearside carriageway level which would obstruct the visibility splay. The visibility splays shall be maintained free of obstruction at all times thereafter for the lifetime of the development.

Reason: To ensure motorists have clear and unrestricted views of approaching cyclists/vehicles in the interest of highway safety.

Post occupation management

17. Management Statement

The development hereby approved shall be undertaken, maintained and managed in full accordance with the Filwood Multi Use Games Area Management Statement Version 2, submitted on the 1st December 2023.

Reason: To protect the residential amenities of neighbouring occupiers and the general character of the area.

18. Floodlighting - Time Restriction

The floodlighting hereby approved shall only operate between the following hours:

17.00 to 20.00 Monday to Friday

10.00 to 20.00 Saturdays

10.00 to 18.00 Sundays

Reason: To protect the residential amenities of neighbouring occupiers from late night floodlighting and noise pollution.

19. Artificial Lighting (external)

Any light created by reason of the development shall not exceed the maximum values of vertical illuminance on premises as detailed in table 3 of the Institute of Light Engineers Guidance Note 01/21 The Reduction of Obtrusive Lighting.

Reason: In order to safeguard the amenities of adjoining residential occupiers.

20. Installation of CCTV

The approved CCTV system shall be installed and made operation prior to the commencement of use.

Reason: In the interest of residential amenity, safety and security.

21. Landscaping

The landscaping/planting proposals hereby approved (shown on drawing 22-010 07 Rev A) shall be carried out no later than during the first planting season following the date when the development hereby permitted is ready for occupation or in accordance with a program, details of which shall be submitted to and agreed in writing by the Local Planning Authority. All planted materials shall be maintained for 5 years and any trees removed, dying, being severely damaged or become seriously diseased within 5 years of planting shall be replaced with others of a similar size and species to those originally required to be planted.

Development Control Committee A – 24 January 2024**Application No. 23/03423/FB : Filwood Park Playing Fields Creswicke Road Bristol BS4 1UA**

Reason: To ensure that the appearance of the development is satisfactory and in line with Bristol City Council Policy DM17.

List of approved plans

22. List of approved plans and drawings

The development shall conform in all aspects with the plans and details shown in the application as listed below, unless variations are agreed by the Local Planning Authority in order to discharge other conditions attached to this decision.

P05-03 Rev B MUGA Design Option 5 Crewsicke & Manning Rd Access General Arrangement, received 7 December 2023
 22-010 09 Elevations of MUGA fence, received 13 September 2023
 Reptile Survey Report prepared by Avondale Ecology dated September 2023, received 25 September 2023
 CCTV Bracket Information Predator Installation Manual V2.3.00.29.2, received 1 November 2023
 CCTV Information Invictus Ruggedised-Hybrid PTZ Camera, received 1 November 2023
 D05 Rev A Cross sections, received 7 December 2023
 22-010 05 Site location plan, received 13 September 2023
 22-010 06 Rev A Tree Protection Plan, received 15 December 2023
 22-010 07 Rev A Landscape proposals, received 15 December 2023
 HLS6901 Floodlighting plan, received 13 September 2023
 P05-00 Creswicke & Manning Road access general arrangement, received 7 December 2023
 P05-01 Rev A Creswicke & Manning Road access general arrangement, received 7 December 2023
 P05-02 Rev A Creswicke & Manning Road access general arrangement, received 7 December 2023
 Filwood Multi Use Games Area Management Statement Version 2, submitted on the 1st December 2023., received 1 December 2023
 Preliminary Ecological Appraisal (PEA) prepared by Avondale Ecology dated August 2023, received 13 September 2023

Reason: For the avoidance of doubt.

Advices

1 Excavation Works on the Adopted Highway

The development hereby approved includes the carrying out of excavation works on the adopted highway. You are advised that before undertaking any work on the adopted highway you will require a Section 171 (Excavation) Licence from the Highway Authority which is available at www.bristol.gov.uk/highwaylicences

- 2 If works are proposed within the nesting bird period (March to August inclusive), nesting bird checks shall be completed by a suitably qualified ecological consultant to ensure that no breeding birds would be adversely affected including by disturbance by the works. Where checks for nesting birds are required, they shall be undertaken no more than 48 hours prior to the removal of vegetation. If nesting birds are found, a 5m buffer zone shall be implemented and works shall not be carried out in that area until the chicks have fledged.

Supporting Documents

2. Filwood Park Playing Fields, Creswicke Road, BS4 1UA.

1. E22056-P05-01-A Filwood Replacement MUGA Option 5
2. E22056-P05-02-A Filwood Replacement MUGA Option 5
3. E22056-P05-03-B Filwood Replacement MUGA Option 5
4. Proposed Elevations

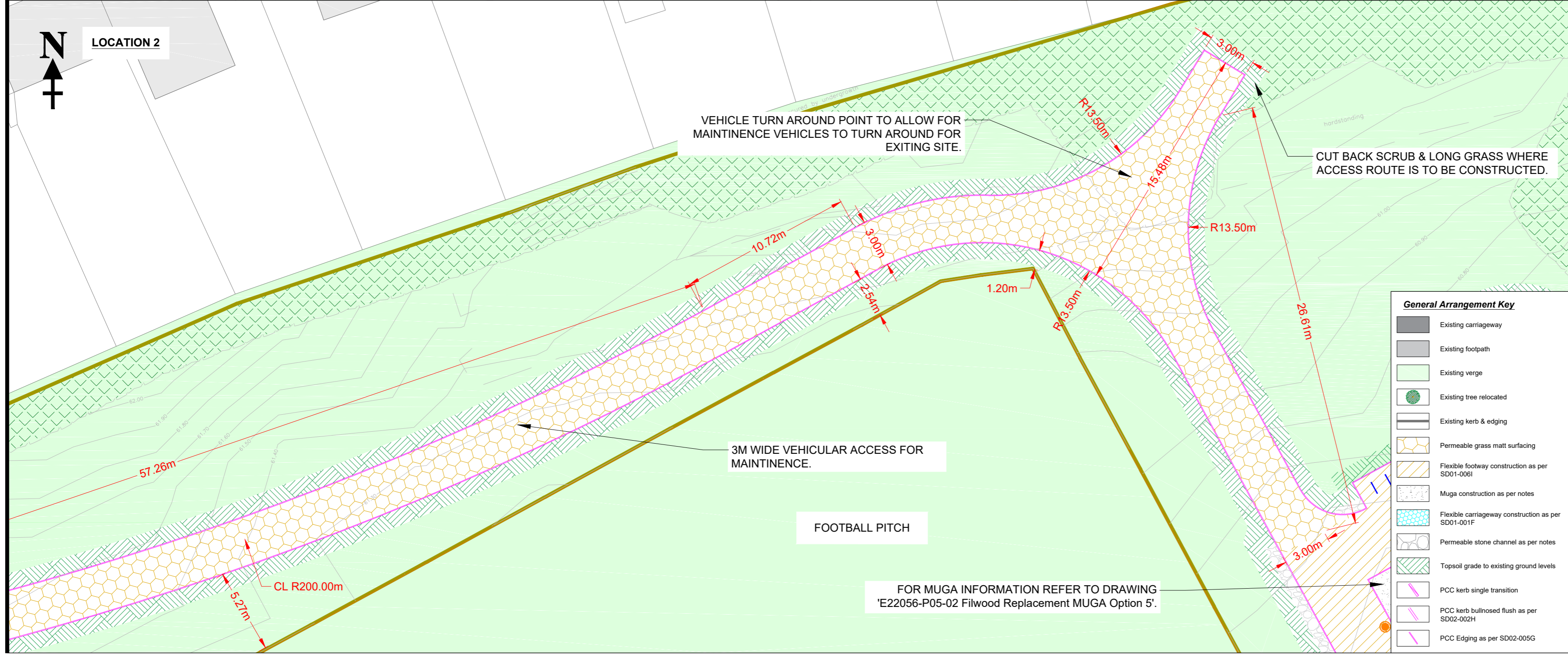
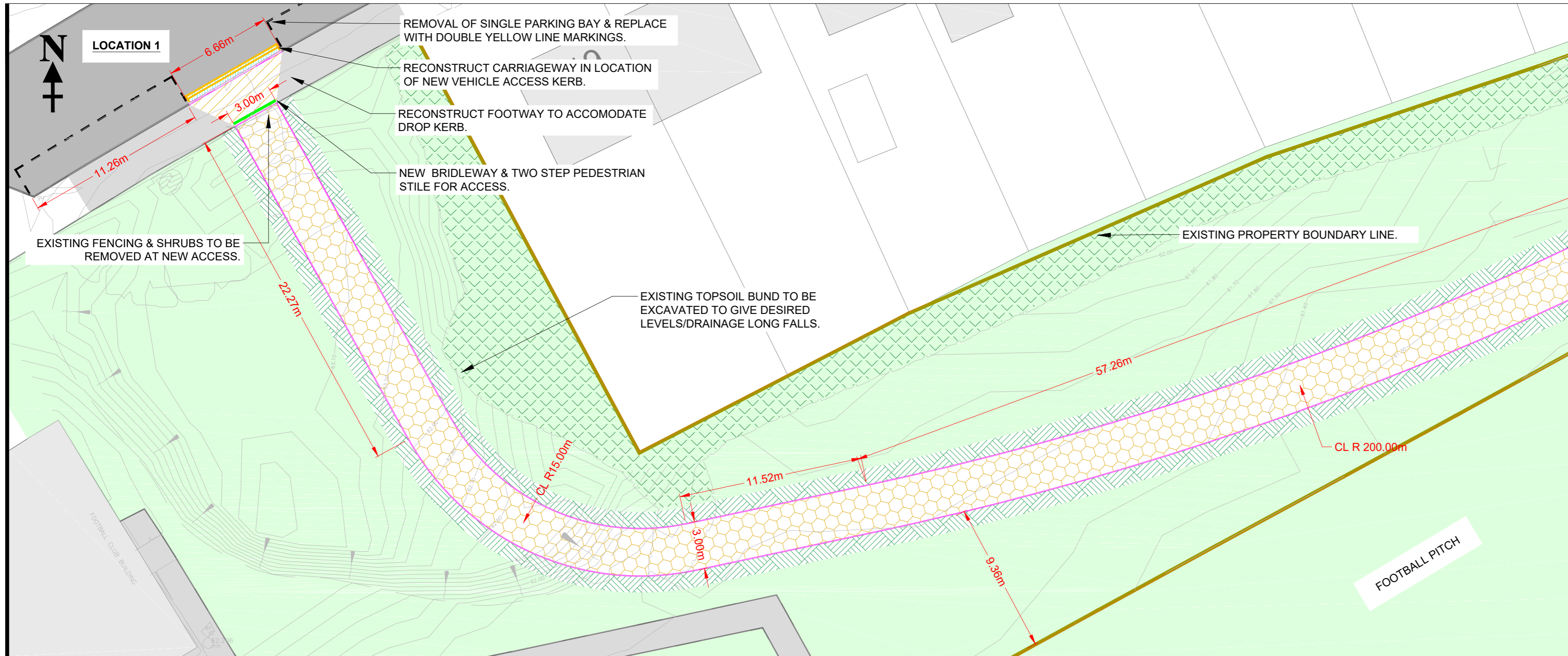

- NOTES:
1. All dimensions are in meters unless otherwise stated.
 2. For SD numbers please refer to Bristol City Council standard drawings.
 3. For road marking diagram numbers - refer to the traffic sign regulations and general directions 2019.
 4. Access to frontages to be maintained at all times unless agreed otherwise with the supervisor.

BRISTOL CITY COUNCIL
TRAFFIC & HIGHWAYS MAINTENANCE
ENGINEERING & DESIGN

PO Box 3399, Bristol City Council, Bristol BS1 9NE
 (C) Crown Copyright and database rights 2023 Ordnance Survey 100023406

Rev.	Date	Description	By
A	28.11.23	Manning Road Access Removed	HHJ

Project
Replacement MUGA
Filwood Broadway
Filwood Park

Title
MUGA Design Option 5
Crewsicke & Manning Rd Access
General Arrangement

Client
Local and Sustainable Transport
Management of Place - Growth & Regeneration
L.E

Drawn by HHJ	Checked by MHB
Date Drawn AUG 2023	Date Issued 28.11.23
Status DRAFT	Issued by HHJ

Scale
1:200 @ A2

Project Number E22056	Drawing - P05-01 -	Revision A
---------------------------------	------------------------------	----------------------

General Arrangement Key

- Existing carriageway
- Existing footpath
- Existing verge
- Existing tree relocated
- Existing kerb & edging
- Permeable grass matt surfacing
- Flexible footway construction as per SD01-006I
- Muga construction as per notes
- Flexible carriageway construction as per SD01-001F
- Permeable stone channel as per notes
- Topsoil grade to existing ground levels
- PCC kerb single transition
- PCC kerb bullnosed flush as per SD02-002H
- PCC Edging as per SD02-005G

FOR MUGA INFORMATION REFER TO DRAWING 'E22056-P05-02 Filwood Replacement MUGA Option 5'.

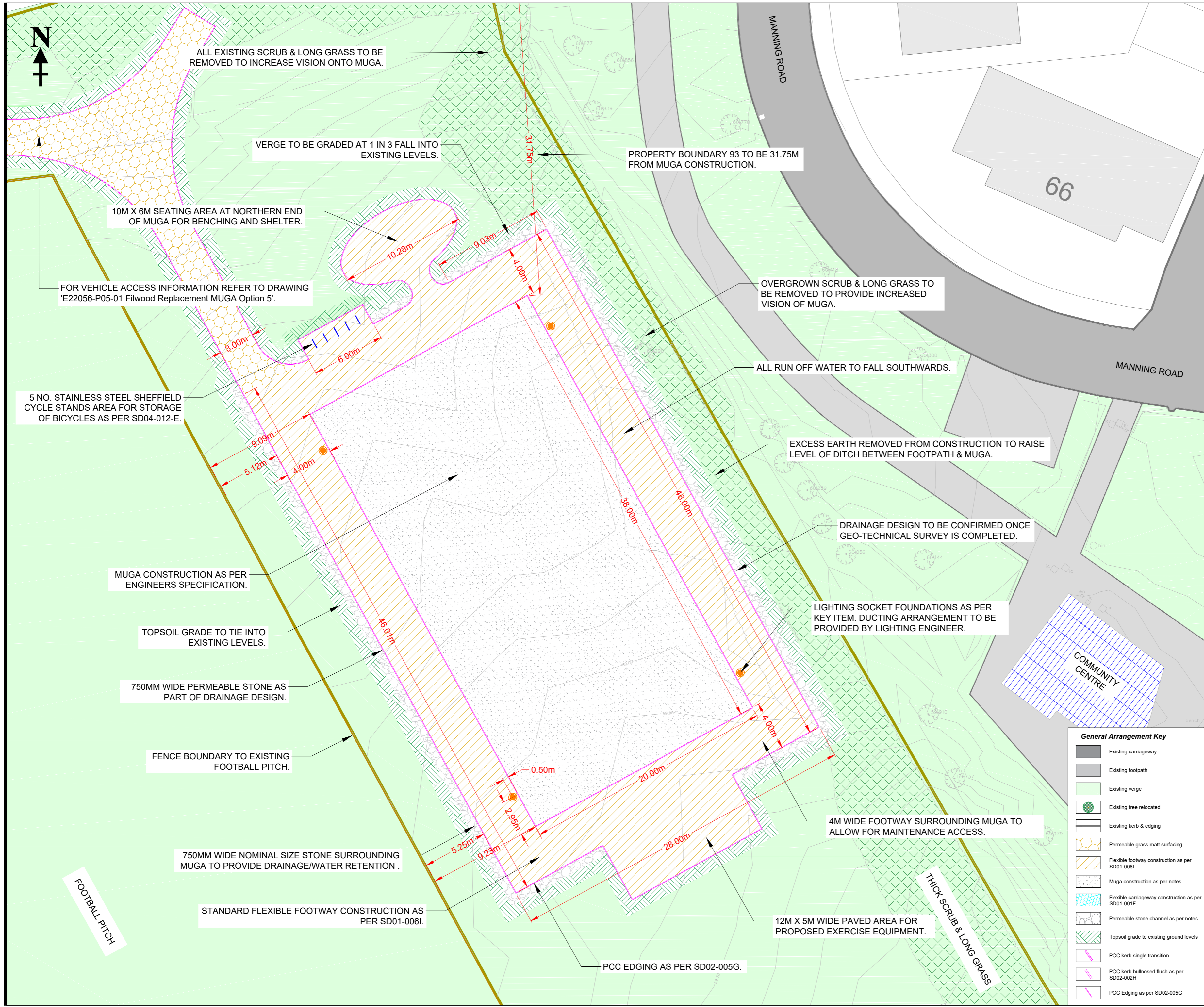

ALL EXISTING SCRUB & LONG GRASS TO BE REMOVED TO INCREASE VISION ONTO MUGA.

VERGE TO BE GRADED AT 1 IN 3 FALL INTO EXISTING LEVELS.

PROPERTY BOUNDARY 93 TO BE 31.75M FROM MUGA CONSTRUCTION.

10M X 6M SEATING AREA AT NORTHERN END OF MUGA FOR BENCHING AND SHELTER.

FOR VEHICLE ACCESS INFORMATION REFER TO DRAWING 'E22056-P05-01 Filwood Replacement MUGA Option 5'.

OVERGROWN SCRUB & LONG GRASS TO BE REMOVED TO PROVIDE INCREASED VISION OF MUGA.

5 NO. STAINLESS STEEL SHEFFIELD CYCLE STANDS AREA FOR STORAGE OF BICYCLES AS PER SD04-012-E.

ALL RUN OFF WATER TO FALL SOUTHWARDS.

EXCESS EARTH REMOVED FROM CONSTRUCTION TO RAISE LEVEL OF DITCH BETWEEN FOOTPATH & MUGA.

MUGA CONSTRUCTION AS PER ENGINEERS SPECIFICATION.

DRAINAGE DESIGN TO BE CONFIRMED ONCE GEO-TECHNICAL SURVEY IS COMPLETED.

LIGHTING SOCKET FOUNDATIONS AS PER KEY ITEM. DUCTING ARRANGEMENT TO BE PROVIDED BY LIGHTING ENGINEER.

TOPSOIL GRADE TO TIE INTO EXISTING LEVELS.

750MM WIDE PERMEABLE STONE AS PART OF DRAINAGE DESIGN.

FENCE BOUNDARY TO EXISTING FOOTBALL PITCH.

750MM WIDE NOMINAL SIZE STONE SURROUNDING MUGA TO PROVIDE DRAINAGE/WATER RETENTION.

4M WIDE FOOTWAY SURROUNDING MUGA TO ALLOW FOR MAINTENANCE ACCESS.

STANDARD FLEXIBLE FOOTWAY CONSTRUCTION AS PER SD01-006I.

12M X 5M WIDE PAVED AREA FOR PROPOSED EXERCISE EQUIPMENT.

PCC EDGING AS PER SD02-005G.

General Arrangement Key

- Existing carriageway
- Existing footpath
- Existing verge
- Existing tree relocated
- Existing kerb & edging
- Permeable grass matt surfacing
- Flexible footway construction as per SD01-006I
- Muga construction as per notes
- Flexible carriageway construction as per SD01-001F
- Permeable stone channel as per notes
- Topsoil grade to existing ground levels
- PCC kerb single transition
- PCC kerb bullnosed flush as per SD02-002H
- PCC Edging as per SD02-005G

- NOTES:
- All dimensions are in meters unless otherwise stated.
 - For SD numbers please refer to Bristol City Council standard drawings.
 - For road marking diagram numbers - refer to the traffic sign regulations and general directions 2019.
 - Access to frontages to be maintained at all times unless agreed otherwise with the supervisor.

BRISTOL CITY COUNCIL
TRAFFIC & HIGHWAYS MAINTENANCE
ENGINEERING & DESIGN

PO Box 3399, Bristol City Council, Bristol BS1 9NE

(C) Crown Copyright and database rights 2023 Ordnance Survey 100023406

Rev.	Date	Description	By
A	28.11.23	Manning Road Access Removed	HHJ

Project
Replacement MUGA
Filwood Broadway
Filwood Park

Title
MUGA Design Option 5
Creswicke & Manning Rd Access
General Arrangement

Client
Local and Sustainable Transport
Management of Place - Growth & Regeneration
L.E

Drawn by
HHJ
 Date Drawn
AUG 2023
 Status
PRELIMINARY

Checked by
MHB
 Date Issued
28.11.23
 Issued by
HHJ

Scale
1:200 @ A2

Project Number
E22056

Drawing
- P05-02 -

Revision
A

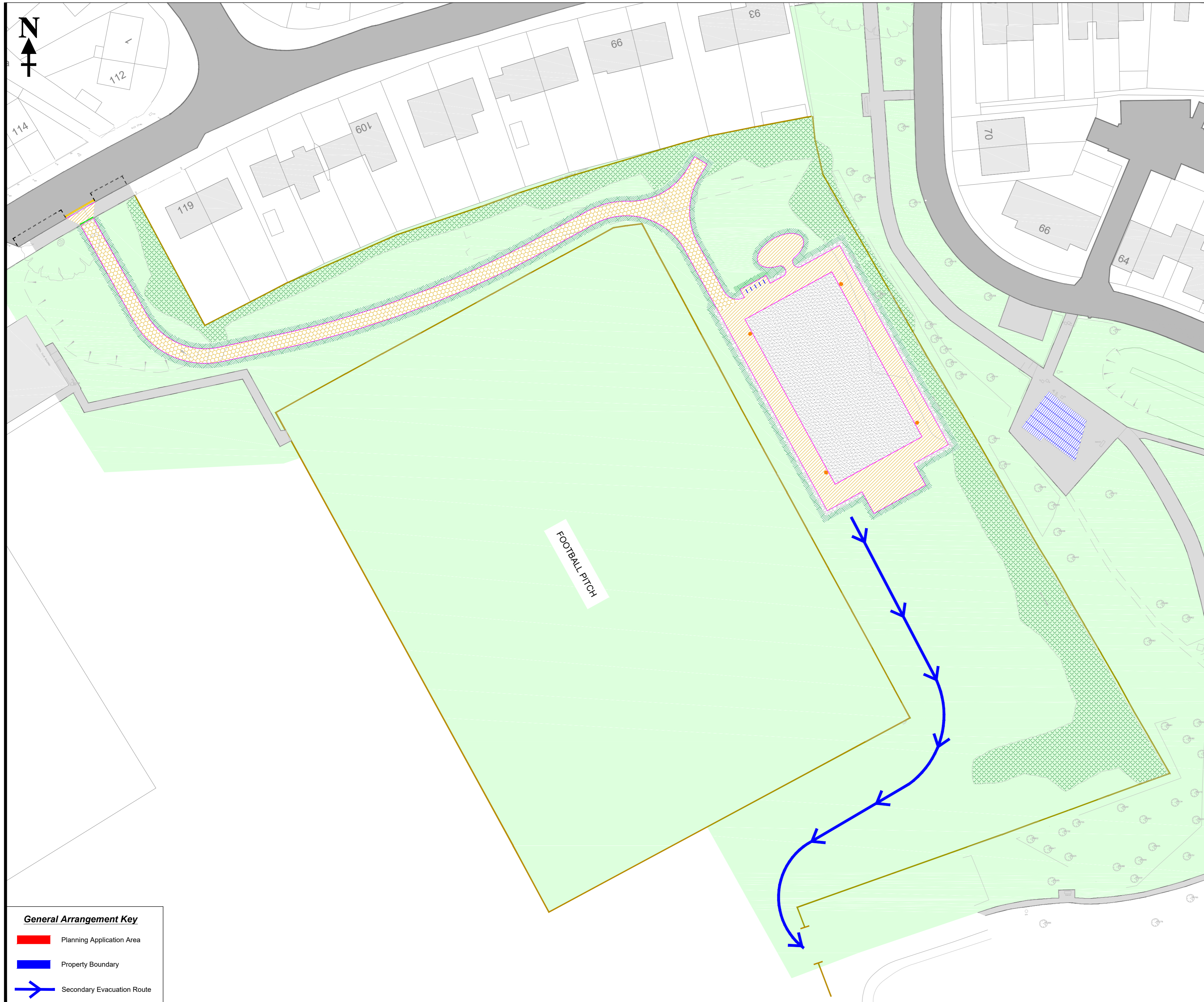

General Arrangement Key

█	Planning Application Area
█	Property Boundary
→	Secondary Evacuation Route

- NOTES:**
1. All dimensions are in meters unless otherwise stated.
 2. For SD numbers please refer to Bristol City Council standard drawings.
 3. For road marking diagram numbers - refer to the traffic sign regulations and general directions 2019.
 4. Access to frontages to be maintained at all times unless agreed otherwise with the supervisor.

BRISTOL CITY COUNCIL
TRAFFIC & HIGHWAYS MAINTENANCE
ENGINEERING & DESIGN

PO Box 3399, Bristol City Council, Bristol BS1 9NE

(C) Crown Copyright and database rights 2023 Ordnance Survey 100023406

Rev.	Date	Description	By
B	28.11.23	Manning Road Access Removed	HHJ
A	01.09.23	MUGA Surround Changes	HHJ

Project
Replacement MUGA
Filwood Broadway
Filwood Park

Title
MUGA Design Option 5
Crewsicke & Manning Rd Access
General Arrangement

Client
Local and Sustainable Transport
Management of Place - Growth & Regeneration
L.E

Drawn by HHJ	Checked by MHB
Date Drawn AUG 2023	Date Issued 28.11.23
Status PRELIMINARY	Issued by HHJ

Scale
1:500 @ A2

Project Number E22056	Drawing - P05-03 -	Revision B
---------------------------------	------------------------------	----------------------

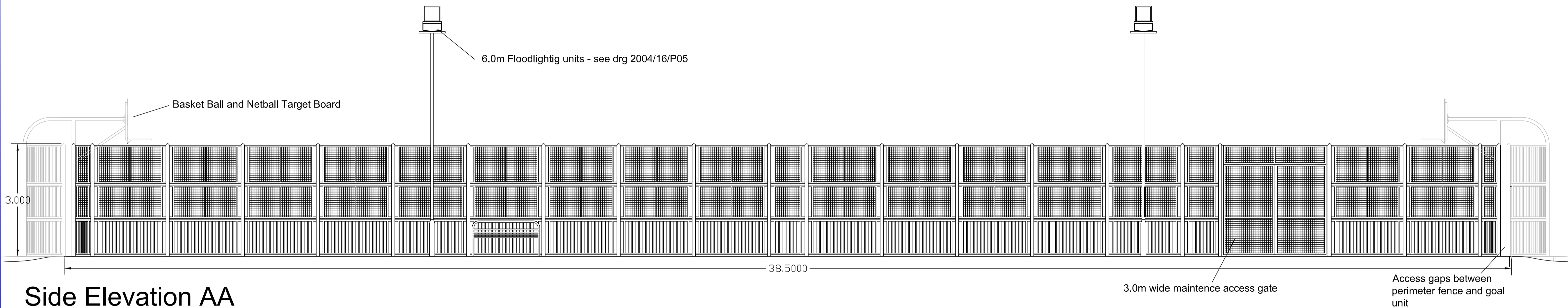

Side Elevation AA

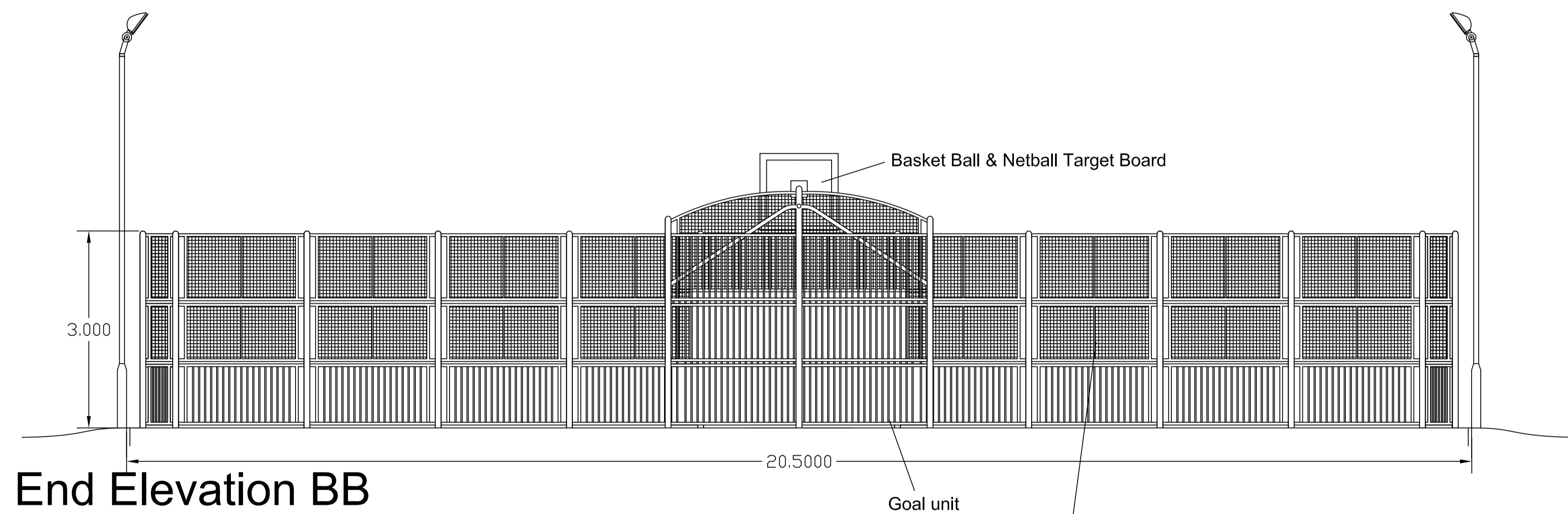

End Elevation BB

- New Ball Court Fencing System:
- 1.0 internal rebound panel at ground level to all fence panels
 - Two Accessible chicane pedestrian gates
 - 3.0m wide x 2.4m high maintenance access gate
 - Post colour- tba
 - Fence panel colour - tba
 - Polyester powder coated finish

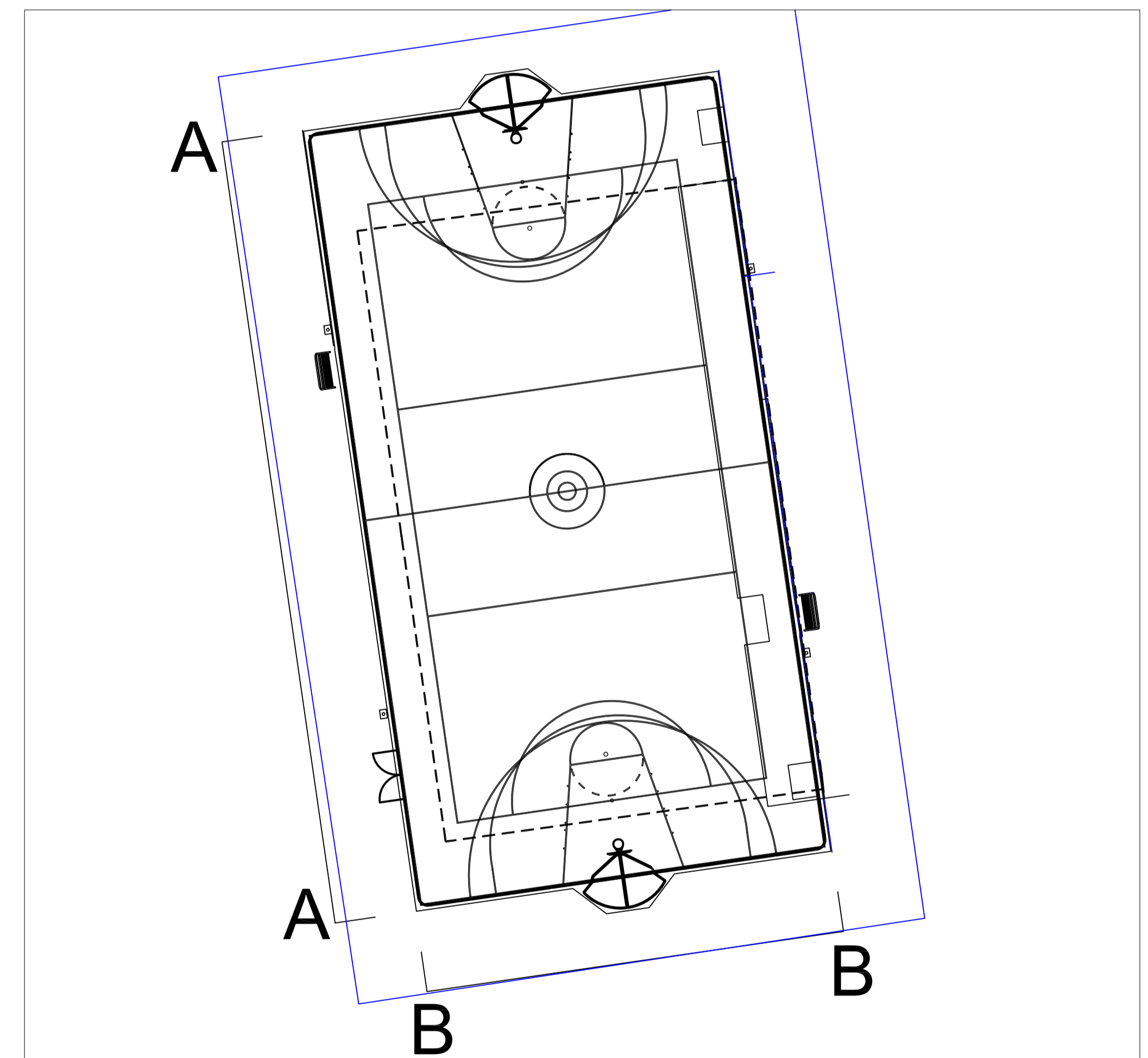

Plan of Muga showing location of fence elevations 1:200

Elevations of Proposed Muga Fence 1:100

Rev	Description	Date
Client	Housing Strategy & Delivery	
Project Title	Filwood MUGA	
Drawing Title	Elevations of MUGA fence	
Information Status	Outline	
Project / Dwg No.	Revision	Scale
CDG 22-010 09		1:100@A1
Date	Drawn	Checked
24.7.23	LE	CB
<small>PO Box 3399, Bristol City Council, Bristol, BS1 9NE © Crown Copyright and database rights 2023 Ordnance Survey 100023406 Bristol City Council, Engineering & Design</small>		